

PT613PB INST

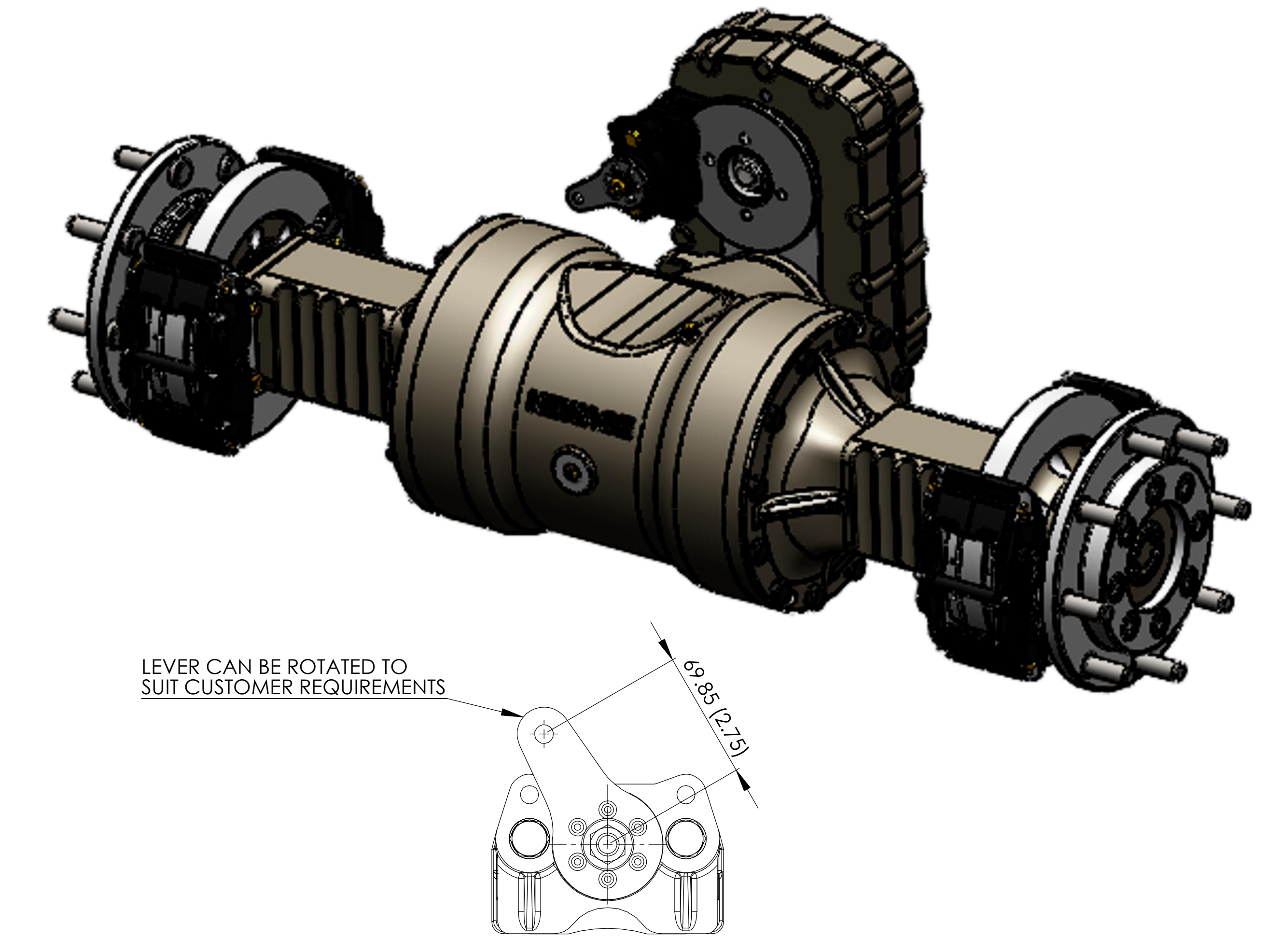
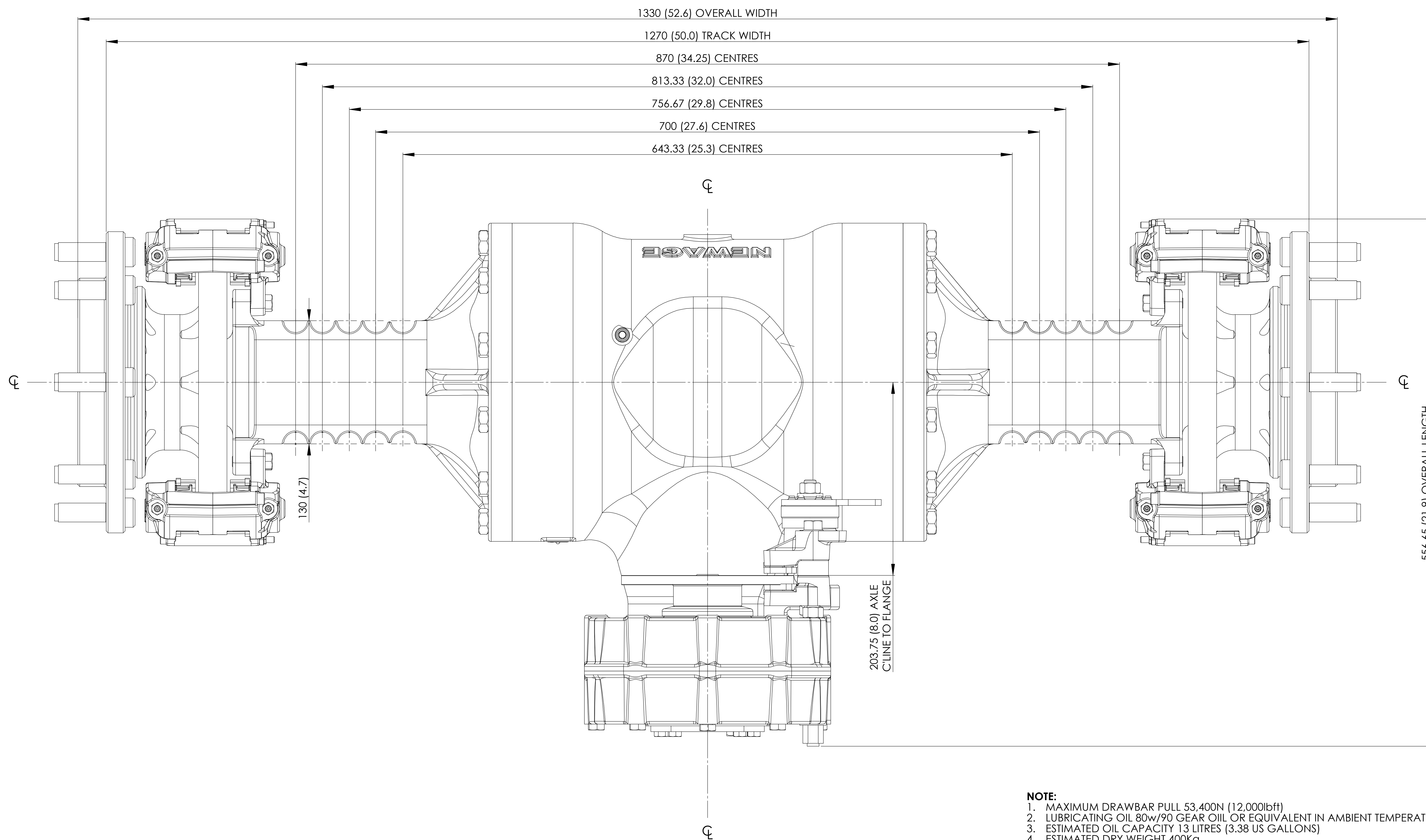
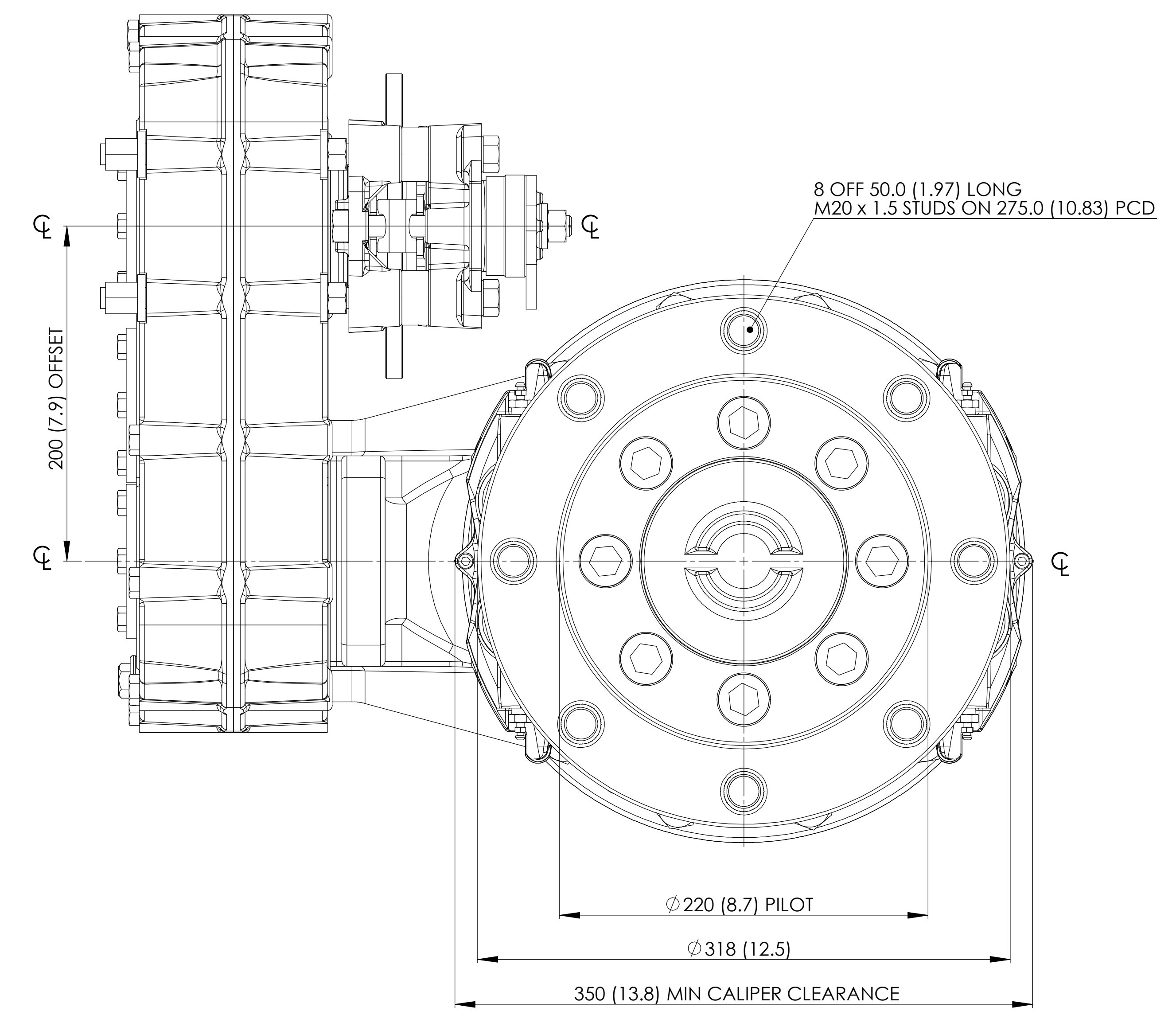
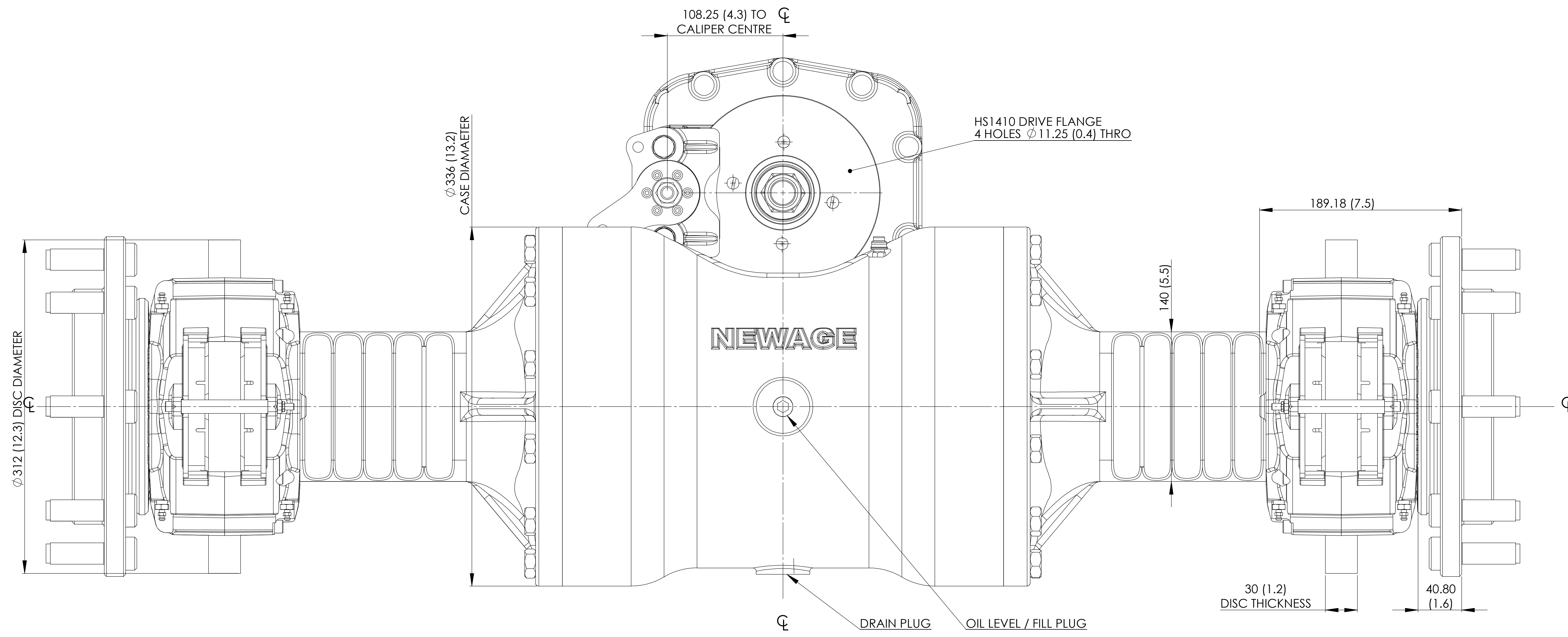

PARK BRAKE DETAIL VIEW SCALE 1:2

- NOTE:**
1. MAXIMUM DRAWBAR PULL 53,400N (12,000lbf)
 2. LUBRICATING OIL 80w/90 GEAR OIL OR EQUIVALENT IN AMBIENT TEMPERATURES 0-30 °C (32 - 86 F)
 3. ESTIMATED OIL CAPACITY 13 LITRES (3.38 US GALLONS)
 4. ESTIMATED DRY WEIGHT 400Kg
 5. AXLE SUPPLIED WITHOUT WHEEL NUTS
 6. MOUNTING PCD OF WHEEL INCREASED TO 275 (10.8") TO ACCOMODATE LARGER WHEEL
 7. MOUNTING CENTRES MOVED 14.2 (0.56") FROM CENTRE ACROSS WHOLE AXLE

THIS DOCUMENT IS CONFIDENTIAL AND IS THE PROPERTY OF PRM MARINE LIMITED. IT IS SUPPLIED ON THE EXPRESS CONDITION THAT IT MAY NOT BE LOANED, COPIED OR DISCLOSED TO ANY THIRD PARTY AND MUST BE RETURNED ON DEMAND.		DRAWN: D. MOORE	SIGNED:	<p>PRM MARINE LIMITED BARLOW ROAD ALDERMAN'S GREEN IND. EST. COVENTRY CV2 2LD Tel: +44 (0)24 7661 7141 Fax: +44 (0)24 7661 1845 Email: design@prm-marine.com Web: www.prm-marine.com</p>
APPROVED: M. HARRIS		SIGNED:	ISSUE: C	
DO NOT SCALE, IF IN DOUBT ASK:	SHEET No: 1 of 1	STATUS: PROTOTYPE	SCALE: 1:2	DATE: 29/08/2013
DIMENSIONS IN mm (I.O.S.) GENERAL MC FINISH (FA 6.3) THREADS TO BREAK FIT (H7/G6) WHO/E DIMENSIONS = DECIMAL DIMENSIONS = ±0.25 ANGULAR DIMENSIONS = ±0.05°	SHEET SIZE: A0	MATERIAL:	HEAT TREATMENT:	TITLE: PT613PB INSTALLATION TRACK
PART No: PT613PB INST				

PART No: PT613B INST

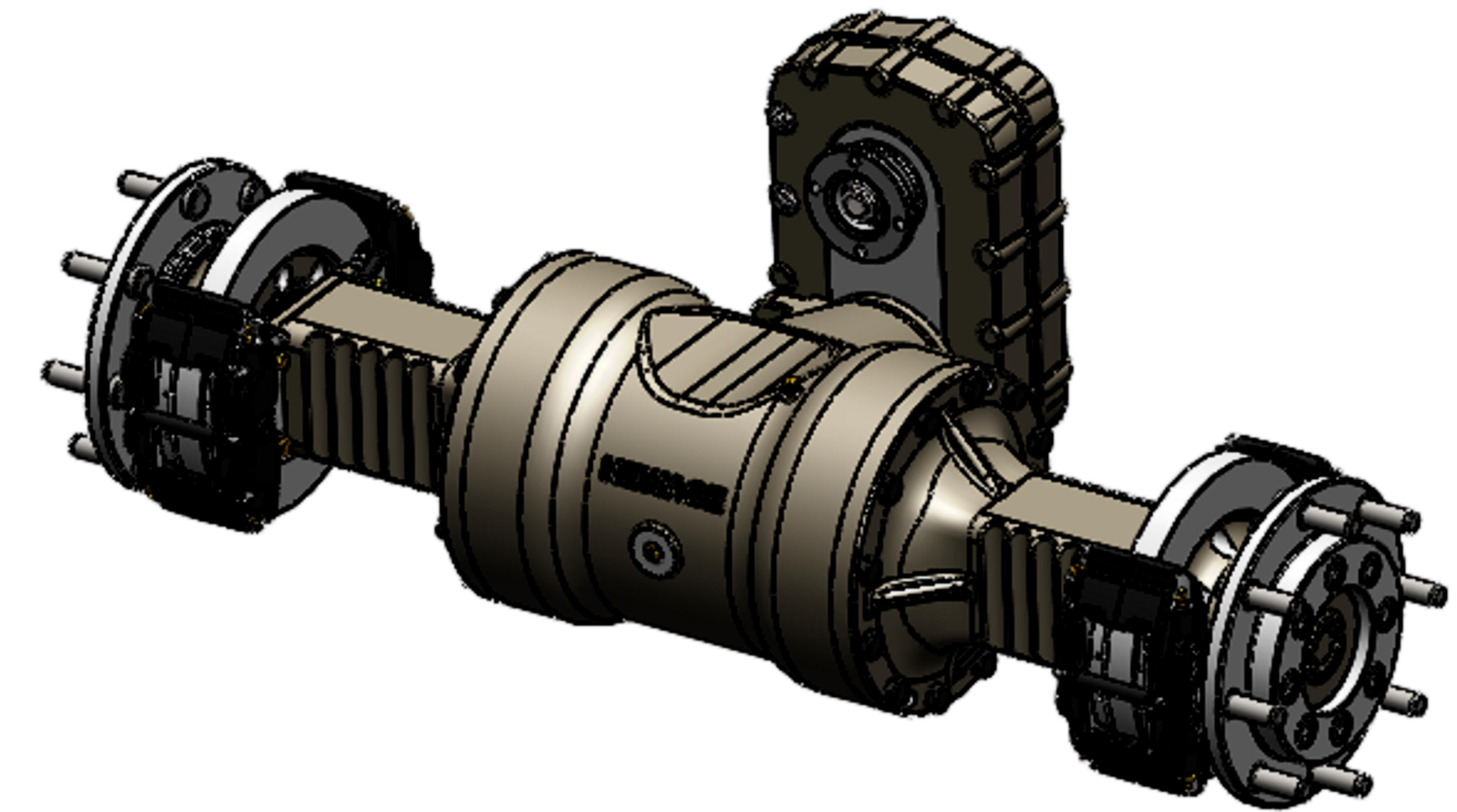
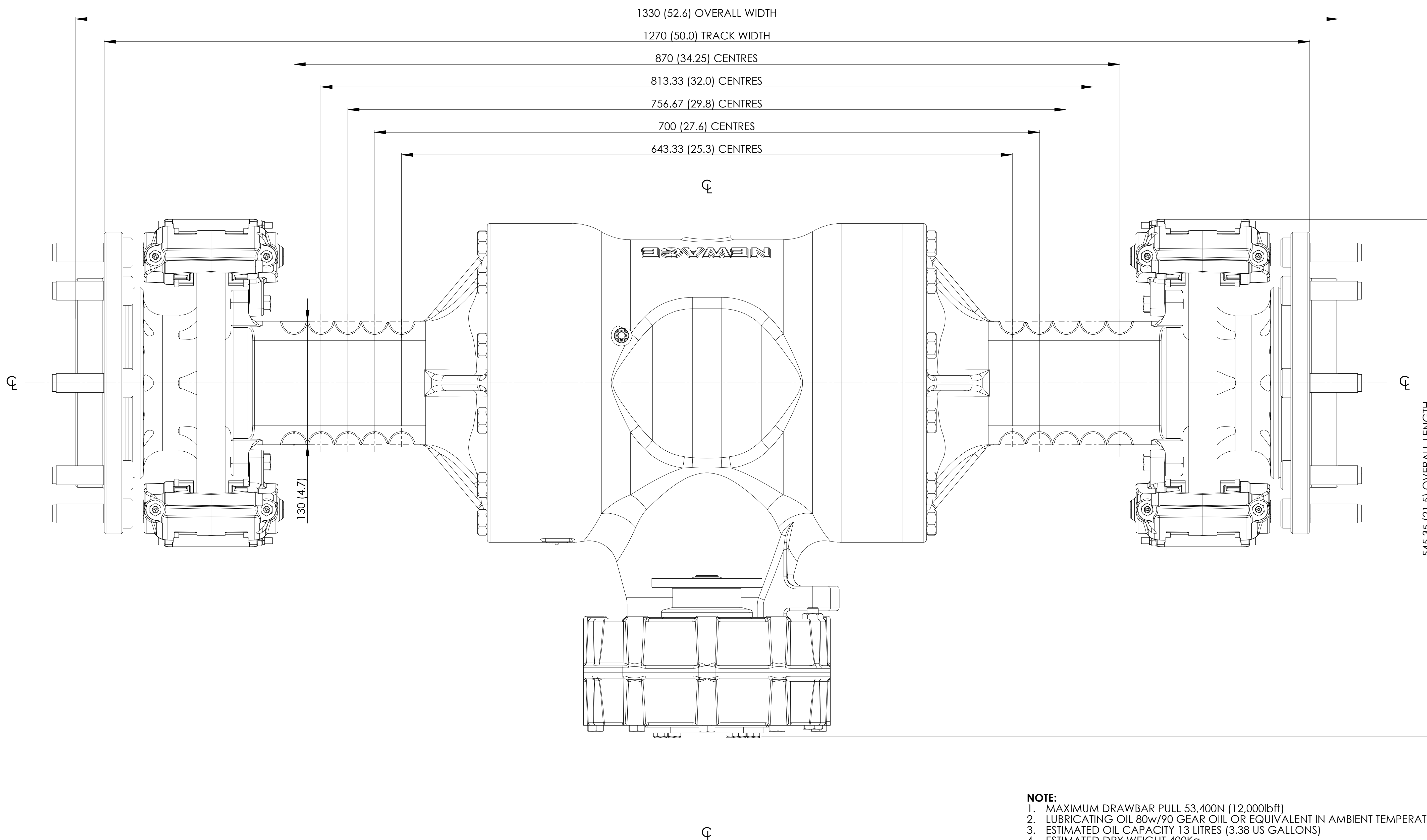
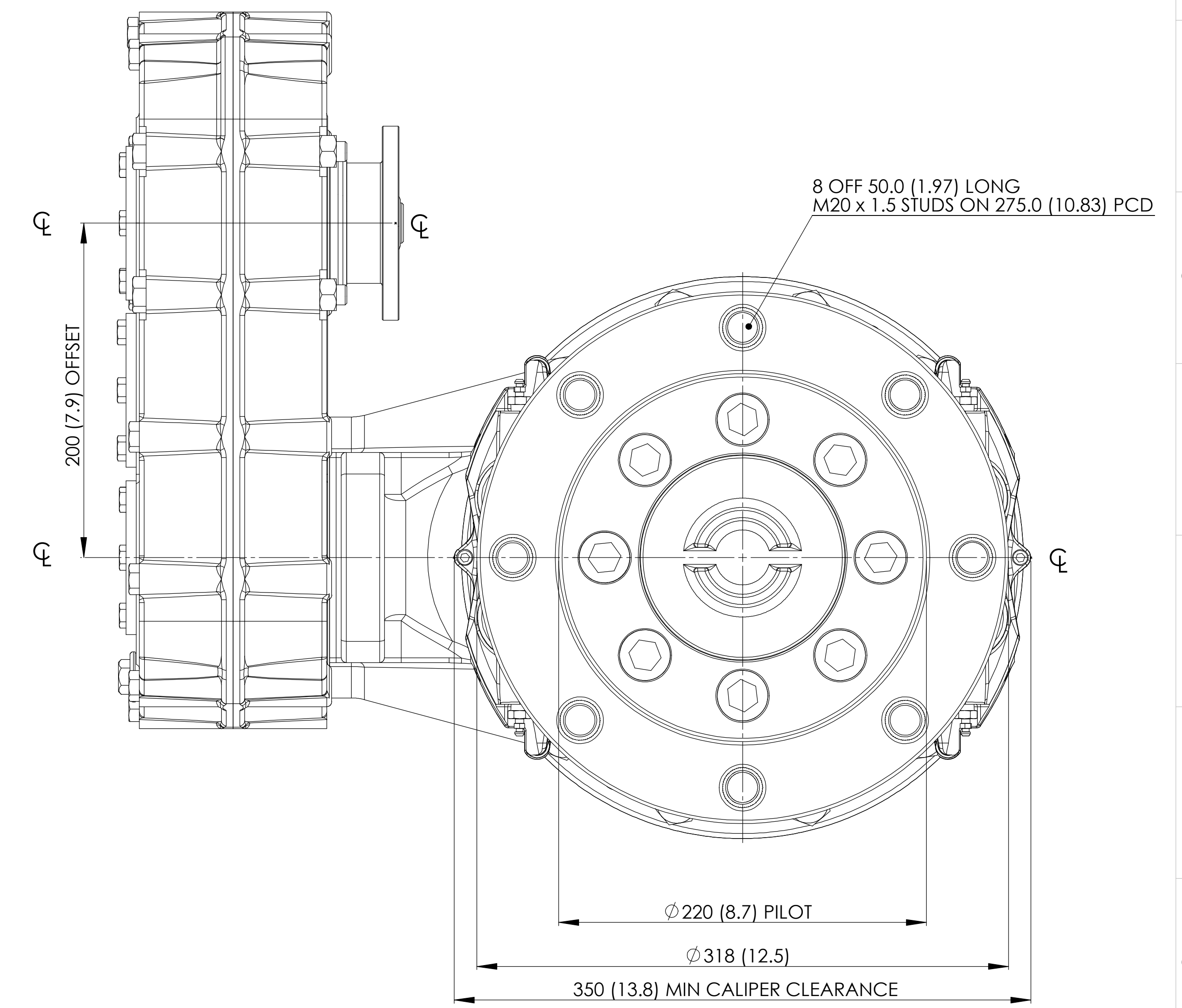
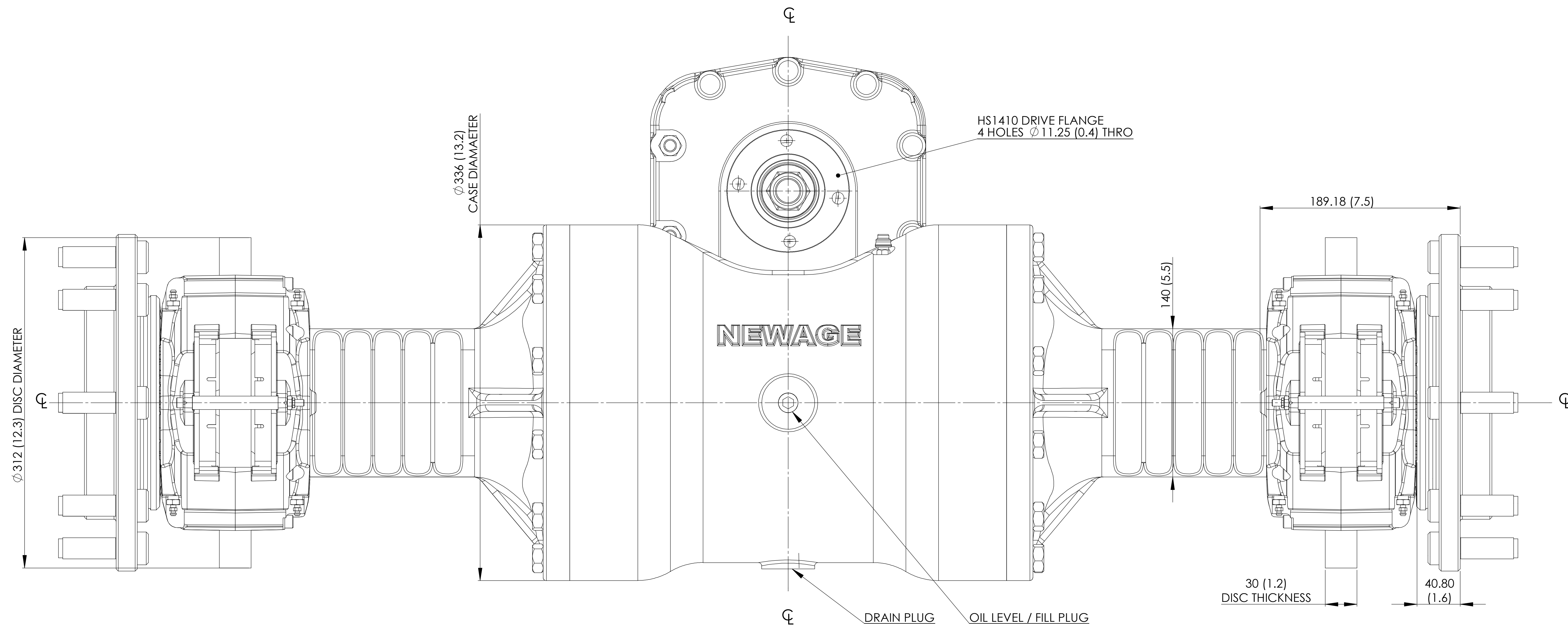

- NOTE:**
1. MAXIMUM DRAWBAR PULL 53,400N (12,000lbf)
 2. LUBRICATING OIL 80w/90 GEAR OIL OR EQUIVALENT IN AMBIENT TEMPERATURES 0-30 °C (32 - 86 F)
 3. ESTIMATED OIL CAPACITY 13 LITRES (3.38 US GALLONS)
 4. ESTIMATED DRY WEIGHT 400Kg
 5. AXLE SUPPLIED WITHOUT WHEEL NUTS
 6. MOUNTING PCD OF WHEEL INCREASED TO 275 (10.8") TO ACCOMODATE LARGER WHEEL
 7. MOUNTING CENTRES MOVED 14.2 (0.56") FROM CENTRE ACROSS WHOLE AXLE

ISS	MODIFICATION DESCRIPTION	BY	DATE	MOD No
C	128 (5.0) DIM CHANGED TO 140 (5.5) TO REFLECT 613-0020 CASTING MOD	DM	28/11/14	PRE PROD
B	612-0020 REPLACED BY 613-0020 MOUNTING CENTRES UPDATED	DM	08/11/14	PRE PROD

THIS DOCUMENT IS CONFIDENTIAL AND IS THE PROPERTY OF PRM MARINE LIMITED. IT IS SUPPLIED ON THE EXPRESS CONDITION THAT IT MAY NOT BE LOANED, COPIED OR DISCLOSED TO ANY THIRD PARTY AND MUST BE RETURNED ON DEMAND.

DO NOT SCALE, IF IN DOUBT ASK: SHEET No: 1 of 1 STATUS: PROTOTYPE SCALE: 1:2 DATE: 29/08/2013

DRAWN: D. MOORE SIGNED: APPROVED: M. HARRIS SIGNED: HEAT TREATMENT: ISSUED: C

TITLE: PT613B INSTALLATION TRACK PART No: PT613B INST

PRM MARINE LIMITED
BARLOW ROAD
ALDERMAN'S GREEN IND. EST.
COVENTRY CV2 2LD
Tel: +44 (0)24 7661 7141
Fax: +44 (0)24 7661 1845
Email: design@prm-marine.com
Web: www.prm-marine.com