

612 WORKSHOP MANUAL

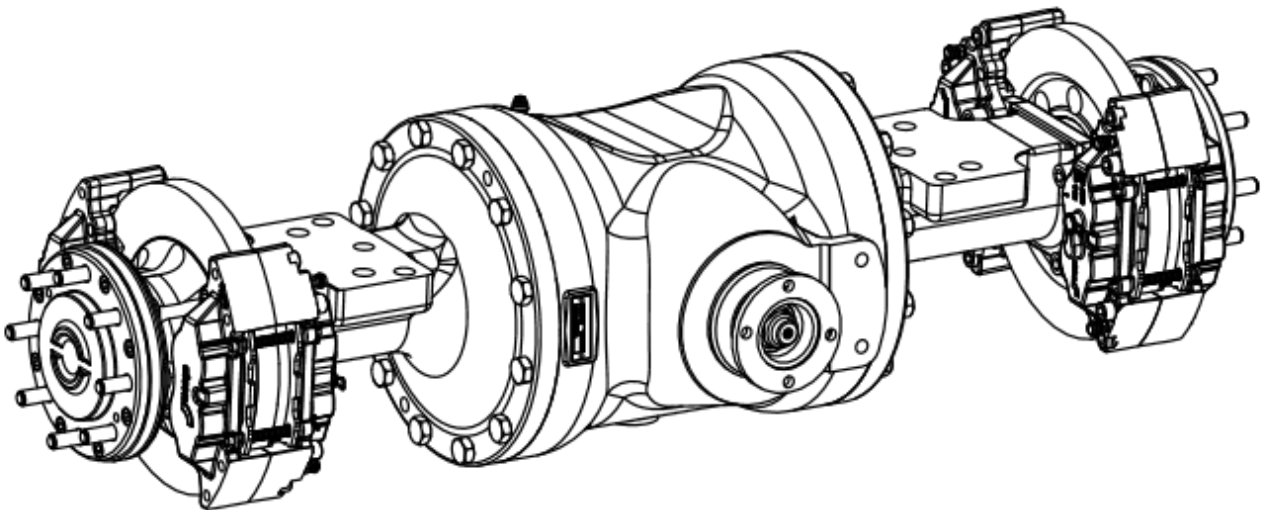



NEWAGE

PRM NEWAGE LIMITED

BARLOW ROAD
COVENTRY
CV2 2LD
ENGLAND

TELEPHONE: +44 (0)24 7661 7141

FAX: +44 (0)24 7661 1845

EMAIL: mail@prm-newage.com

WEBSITE: www.prm-newage.com

612 Service Manual

Issue: **2.4**

Created By: S Hylands

Updated Dated: January 2020

PRM Newage Ltd operates a policy of product improvement and therefore reserves the right to change specifications without prior notification. Whilst every effort is made to ensure complete accuracy of the information in this manual no liabilities for inaccuracies or the consequences thereof can be accepted by the manufacturer or the distributor who supplied the manual.

The following international symbols are used in this service manual:



WARNING! THIS SYMBOL WARNS OF POSSIBLE PERSONAL INJURY



CAUTION! THIS SYMBOL WARNS OF POSSIBLE DAMAGE TO TRANSMISSION

CONTENTS

INTRODUCTION	5
GENERAL DATA	5
Description	5
Specification	5
IDENTIFICATION	7
GENERAL SERVICE INFORMATION	8
Routine Maintenance	8
Lubricants	8
Greases	8
Brake Fluid	8
Liquid Sealant	8
Fasteners – Tightening Torque	9
Axle Backlash	9
Tooling – See Drawings	9
SERVICING AND REPAIRS – GENERAL	14
Seals	14
Bearings	14
Cleaning	14
INSPECTION	15
Main Case and Arms	15
Gears	15
Bearings	15
Threaded Parts	15
PROCEDURES	15
Section ‘A’ – Axle Exploded Diagram	16
Section ‘B’ – Main Case and Differential Assembly	17
Servicing the Main Case and Differential Assemblies	19
Removing the Differential	19
Servicing the Differential Assembly	19
Removing the Pinion from the Main Case	20
Pinion Shimming Procedure for tooth contact pattern of the Crown Wheel & Pinion (B10) with either Collapsible Spacer (B8A) or Solid Spacer (B8) used.	20
Pinion Shimming Procedure for the Pinion Bearings (B7 & B9) Pre-Load using Solid Spacer (B8) & Shims (B13) ..	21
Fitting the Pinion in the Main Case - Using Collapsible Spacer (B8A)	21
Fitting the Pinion in the Main Case - Using Hard Spacer and Shims (B8 & B13)	22
Section ‘C’ – Planet Carrier Assembly	23

Servicing the Planet Carrier Assemblies	24
Removing the Annulus Gear	24
Section 'D' – Axle Arm, Hub and Brake Assemblies	25
Servicing the Axle Arm, Hub and Brake Assemblies	29
Servicing the Brake Pad Assemblies	30
Section 'E' – Park Brake Assembly.....	31
Servicing the Park Brake Assembly.....	32
Replacing the Park Brake Calliper Pads	32
Park Brake Overhaul.....	33
Mounting Procedure.....	34
Adjustment Procedure.....	34
Lining Replacement	34
SPARES KITS.....	36
SPIRAL BEVEL GEAR TOOTH CONTACT.....	41
Correct Pattern	41
Incorrect Pattern	41
NOTES.....	44

INTRODUCTION

Spare parts for Newage axles may only be obtained from the original equipment manufacturer and not directly from Newage. Always quote your vehicle/machine serial number and axle serial number – see section titled 'Identification'.

As a clarification in the manual where there is a designation of a number followed by the word “off”, for example “8 off” this indicates that there are a quantity of the designated part as a multiple of 8.

If possible, the repair/service should be carried out in a clean environment. Where this is not possible, and the work must be completed on site, appropriate measures must be taken to ensure that dirt or foreign matter does not enter the unit. Newage axles are designed to operate in the arduous conditions found in the construction industry; providing they are maintained regularly they will provide the service our customers expect from Newage products.

GENERAL DATA

Description

The 612 series axle is a double reduction unit featuring a Hydraulic Disc Braking system.

The Input Coupling is meshed with the 1st reduction Spiral Bevel Pinion and Crown Wheel driving a 4 Pinion Differential. Final drive is transmitted via the 2nd reduction in-board Planetary Assemblies. The Axle Shafts are fully floating (i.e. not subjected to wheel loads) with each Wheel Hub supported on opposed taper Roller Bearings.

Specification

Overall Ratio (:1) 13.2 / 15.79 / 19.74

Input Flange Hardy Spicer (SAE) 1410

Axle Mounting

Pad Mounting Centres: 600mm (23.625" 4Deg) / 660 mm (26" 2 Deg) / 660 mm
(26" 6 Deg) ZERO Deg for Taylor Dunn

Or

Cast Rib mounting Centres: 575mm (22.64"), 640mm (25.20"), 705mm (27.75"), 770mm (30.31"), 835mm (32.87").

Mounting centres, across 120mm (4.72") with cast Rad R12.5mm (0.492").

Wheel Fixing

8 studs: 9/16" x 18 UNF-3A on 165.1mm (6.5") PCD

or

8 studs: M20 x 1.5 on 275mm (10.83") PCD

Maximum Dynamic Load Rating

6500Kg (14,330 lbs) based on 1,219mm (48") wheel track

Maximum Output Torque

Intermittent at both wheels 32,373Nm (23,874 lbft) based on 13.2:1

Maximum Vehicle Drawbar Pull

Stated 62,275N (14,000 lbf)

Service Brakes

Dual Caliper Hydraulic Disc Brakes per wheel, 252mm (9.921") effective diameter x 24mm (0.945") wide case rotor of 300mm (11.811") diameter.

Max brake torque at both wheels

22,600Nm (16,666 lbft) at 1,100psi (76Bar)

Park Brake

Optional (disc mounted) Cable Operated

Approximate weight

340Kg (750lbs) dry weight

Oil Capacity

12.0 litres (3.12 US Gallons)

IDENTIFICATION

If spares are required, please quote the axle model, the vehicle/machine model and serial number from the blue plate. 612 Axles are produced in a variety of configurations for individual customer requirements; therefore, it is important to identify the Axle correctly.

The part number allocated to each Axle describes the basic specification as below:

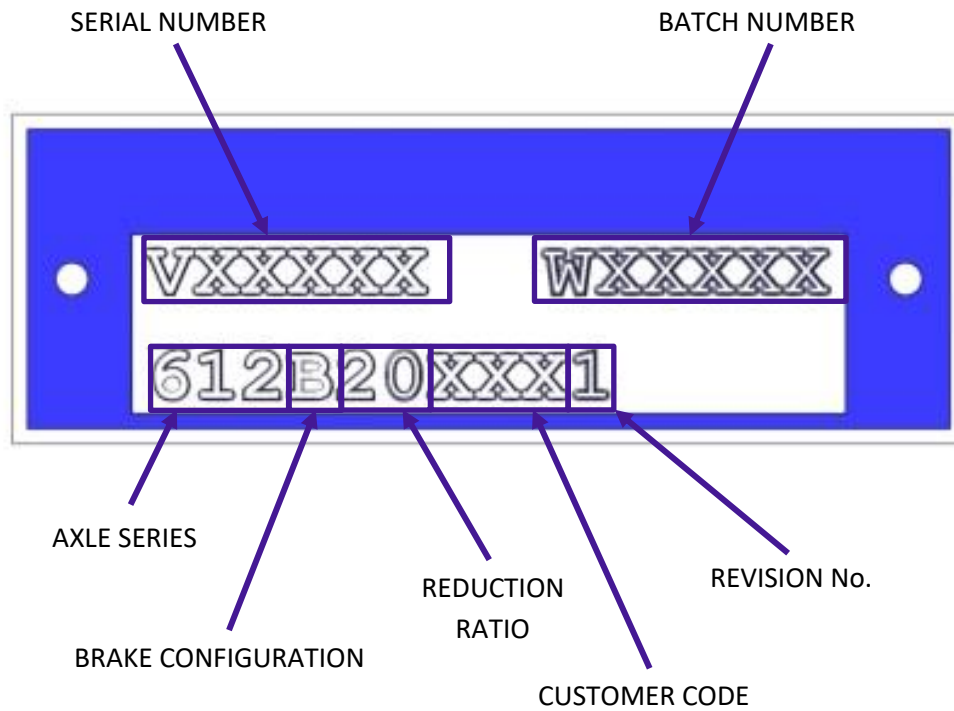

GENERAL SERVICE INFORMATION

Routine Maintenance

Check	Frequency
Axle Oil change	After initial 300 Hrs then every 1,000 Hrs
Axle Oil Level check	Monthly
Axle Shaft Bolts	Monthly
Brake Fluid change	Annually
Brake Fluid Level check	Monthly
Check Axle Arm/Main Case joint securing Bolts	Monthly
Check Wheel Hub Bearing adjustment	1,000 Hrs
Check Wheel Nut	Weekly
Visual check for oil leaks around joints and Seals	Weekly
Prop Shaft Bolts	Monthly
Service Brake Bolts	Weekly

Lubricants

Only those lubricants shown below or their direct equivalents must be used:

- 80W90 Gear oil for operation in ambient temperatures between 0°C and 30°C (32-86°F).

NOTE: An alternative engineering approved Gear oil may be used. Consult 'PRM Newage' before filling the axle.

The oil is added via the combined Filler/Level Plug positioned on the rear of the axle Main Case. When installing new Unitised Hub Seals, ensure the outer surface of the seal and the Inner diameter bore of the Hub is free from grease. Use Loctite SF7063 Solvent Cleaner to degrease both prior to fitment of the seal.

Greases

Smear grease between on other Oil Seal lips and 'O' Rings at major overhauls, or whenever a repair to these areas is performed.

Only those greases shown below, their direct equivalents or alternative engineering approved grease must be used:

- Texaco Multifak EP2

Brake Fluid

The Axle Brakes operate with the fluid specification:

- FMVSS 116 DOT 4, SAEJ1703 and ISO4925 Brake Fluid

NOTE: An ISO VG32 Mineral Hydraulic Fluid must NOT be used under any circumstance.

Liquid Sealant

The Main Case & Axle Arm joint faces must be sealed with either of the following:

- Threebond 1207D Silicon Liquid Gasket

NOTE: An alternative engineering approved silicon sealant may be used.

For locking features the following compound must be used: Loctite 243.

Fasteners – Tightening Torque

Fastener	A/F (mm)	Torque (Nm)	Torque (lb.ft)
Main Case Assembly			
Axle Arm/Main Case Bolts (M16)	24	260	200
Axle Shaft/Wheel Hub Cap Bolts (M10) + Loctite 243	8	100	74
Brake Caliper mounting Cap Bolts (M14) + Loctite 243	12	220	162
Differential Bearing Carrier Cap Bolt (M10)	8	100	74
Differential assembly Nut (M12)	19	98	72
Differential Adjuster Cap Bolts (M6)	5	20	15
Differential Bearing Adjuster Housing – <i>(Special Tool required)</i>	---	20	15
Drain and Level Plug (1/2" BSP)	10	16	12
Hub Assembly Lock Nut (M80) – <i>(Special Tool required for KM16 Nut see TOOLING)</i> <i>Speed Brace & Back off 1 Tab – see page 29</i>	---		
Wheel Nuts (9/16" UNF x 18)	7/8"	230	170
Wheel Adaptor Cap Bolt (M20 x 45)	17	340	250
Wheel Nuts (M20)	30	400-448	295-330
Input Flange Nut M24	36	339	250

Axle Backlash

Assembly	Pinion/Wheel	Drive Flange	P.C.D	Backlash
916-9820	916-2000 916-2010	612-2180 (HS1410) 612-2181 (HS1410) - (613PB ONLY)	95.24mm (3.750")	0.41/0.47mm (0.0161/0.0185")

Tooling – See Drawings

The following tooling is used to aid in the servicing of the axle. These are available from the Original Equipment Manufacturer.

PR30508 – SOCKET SPANNER FOR WHEEL HUB BEARING LOCK NUT 010N801 (D3). ALTERNATIVE TO PR30508 IS KM16 AVAILABLE FROM SKF STOCKISTS, M80 STUB AXLE LOCKNUT 19MM (3/4") SQUARE DRIVE.

PR30919 – SOCKET SPANNER FOR DIFF ADJUSTER NUT 915-2151 (A7)

216-2890Z - SLAVE MEASURING SPACER FOR SHIMMING PINION (B10) PRE-LOAD BEARINGS

ENGINEERING DATA SHEET

ISSUE 1

COMPILED BY N. BAIRD

DATE 28-8-00

PROJECT No. PR 30508

SHEET No.

SUBJECT SPECIAL SPANNER - M80 NUT 010N801 - 615 AXLE

24 A/F HEX. SKT.
1/2" SQ. DRIVE
BRAZE ON HERE

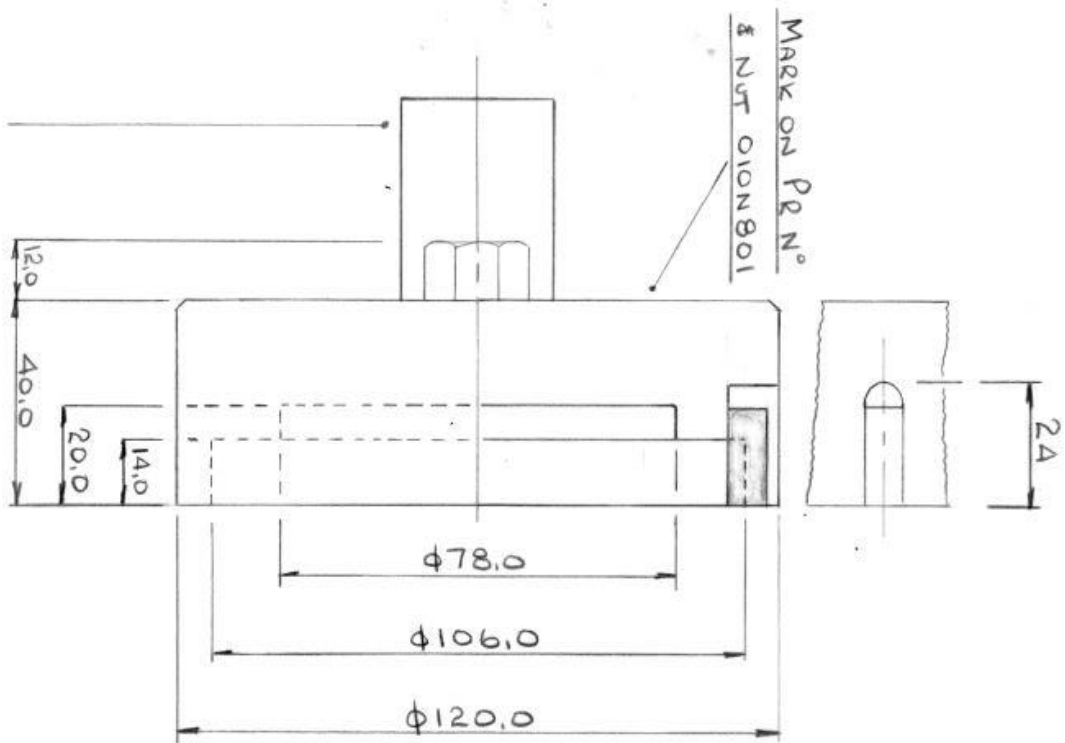

PR 30508

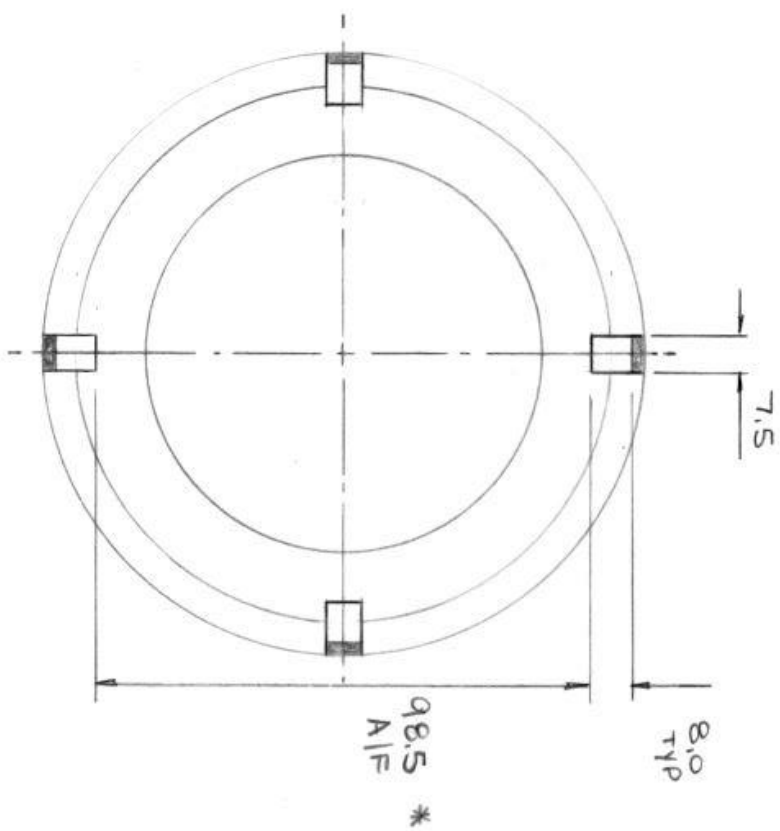

4 KEYS EQUIDISTANT
7.5 A/F TOOL STEEL
BRAZED IN POSITION

* ADJUST AS REQUIRED
TO SUIT ACTUAL NUT

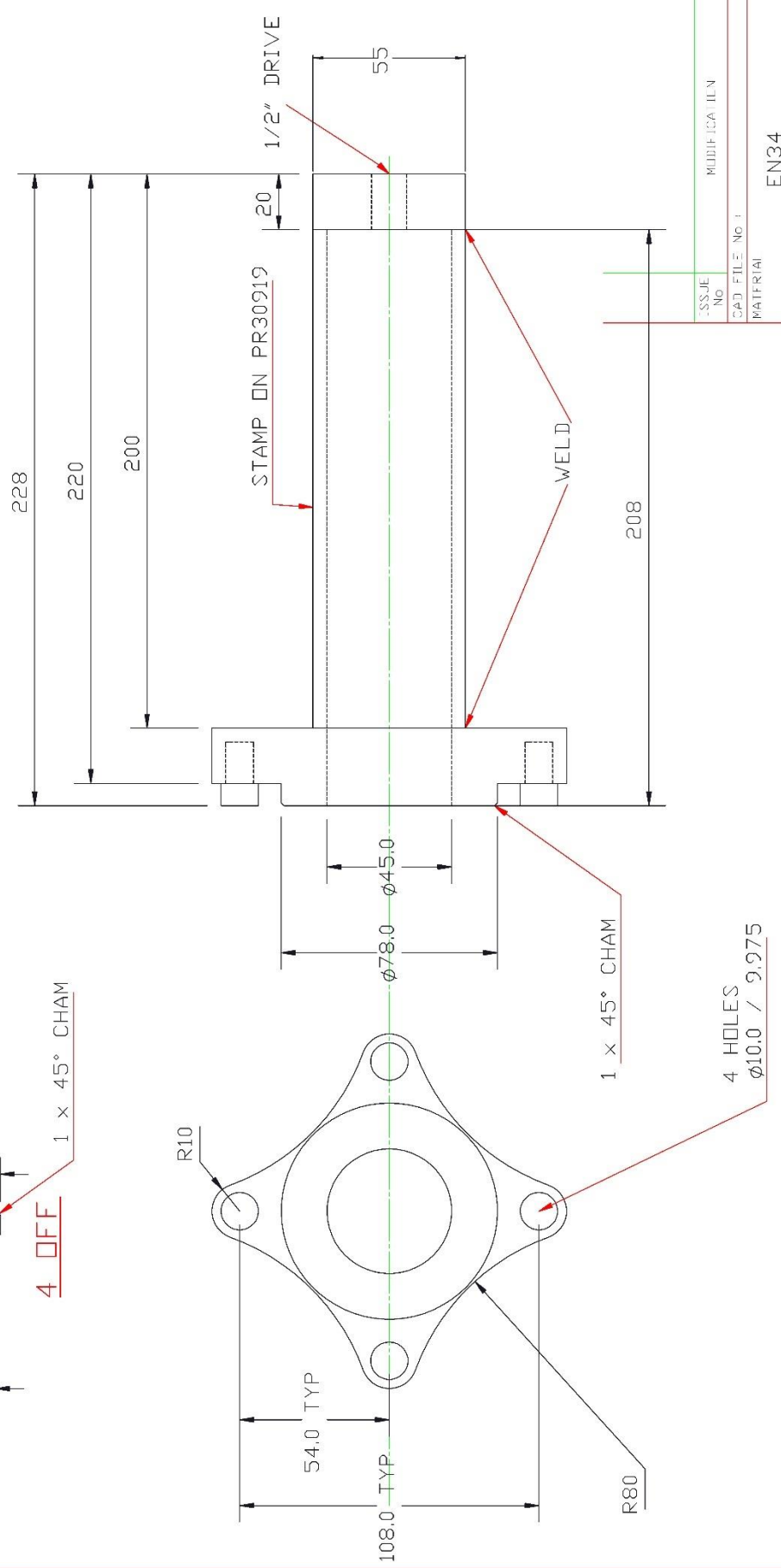

DESIGN No	MODIFICATION
CAD FILE No	
MATERIAL	EN34
HEAT TREATMENT	
CASE HARDEN	

NAME	SIGNET	DATE
DRAWN	S.R	15/05/08
APPROVED		
PART No	PR30919	ISSUE
		A

SCALE	1:1
PROJECTION	

DO NOT SCALE IF IN DOUBT ASK

UNLESS OTHERWISE STATED,
 1. ALL DIMENSIONS ARE IN mm.
 2. TOLERANCES UNLESS OTHERWISE SPECIFIED:
 DECIMAL DIMS TO 0.25mm / ANGULAR DIMS TO 0.5°
 3. SURFACE FINISH 63 MICRON CLA.

THE INFORMATION CONTAINED ON THIS DRAWING MUST NOT BE COPIED OR LENT W/OUT PERMISSION COPYRIGHT © 2000 NEWAGE TRANSMISSIONS LIMITED.

NEWAGE TRANSMISSIONS LIMITED TITLE: FITTING SPANNER FOR 612/613 BEARING ADJUSTER NUT

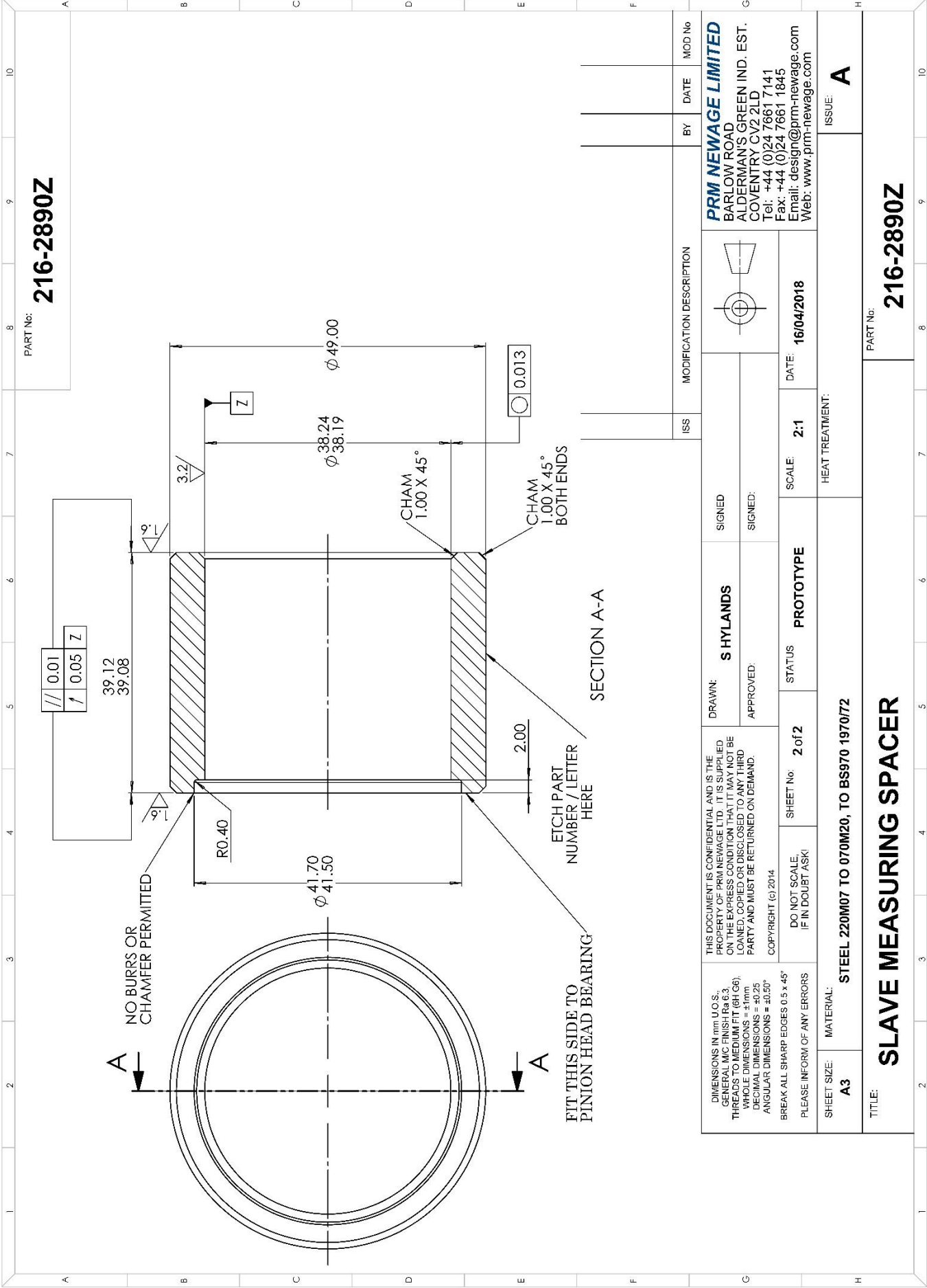

PRM NEWAGE LIMITED
 BARLOW ROAD
 ALDERMAN'S GREEN IND. EST.
 COVENTRY CV2 2LD
 Tel: +44 (0)24 7661 7141
 Fax: +44 (0)24 7661 1845
 Email: design@prm-newage.com
 Web: www.prm-newage.com

ISS	MODIFICATION DESCRIPTION	BY	DATE	MOD No

	SIGNED	DATE: 16/04/2018
	SIGNED:	SCALE: 2:1

HEAT TREATMENT:

STEEL 220M07 TO 070M20, TO BS970 1970/72

TITLE: **SLAVE MEASURING SPACER**

DIMENSIONS IN THE U.O.S. GIVEN TO MIC FINISH TO 3 THREDS TO MEDIUM FIT (H 6G). WHOLE DIMENSIONS = +1mm DECIMAL DIMENSIONS = ±0.25 ANGULAR DIMENSIONS = ±0.50° BREAK ALL SHARP EDGES 0.5 x 45° PLEASE INFORM OF ANY ERRORS	DRAWN: S HYLANDS APPROVED:	STATUS: PROTOTYPE SHEET No: 2 of 2	DATE: 16/04/2018 SCALE: 2:1	ISSUE: A
------------------------------------------------------------------------------------------------------------------------------------------------------------------------------------------------------------------------------------------------	--------------------------------------	-----------------------------------------------------	----------------------------------------------	-----------------

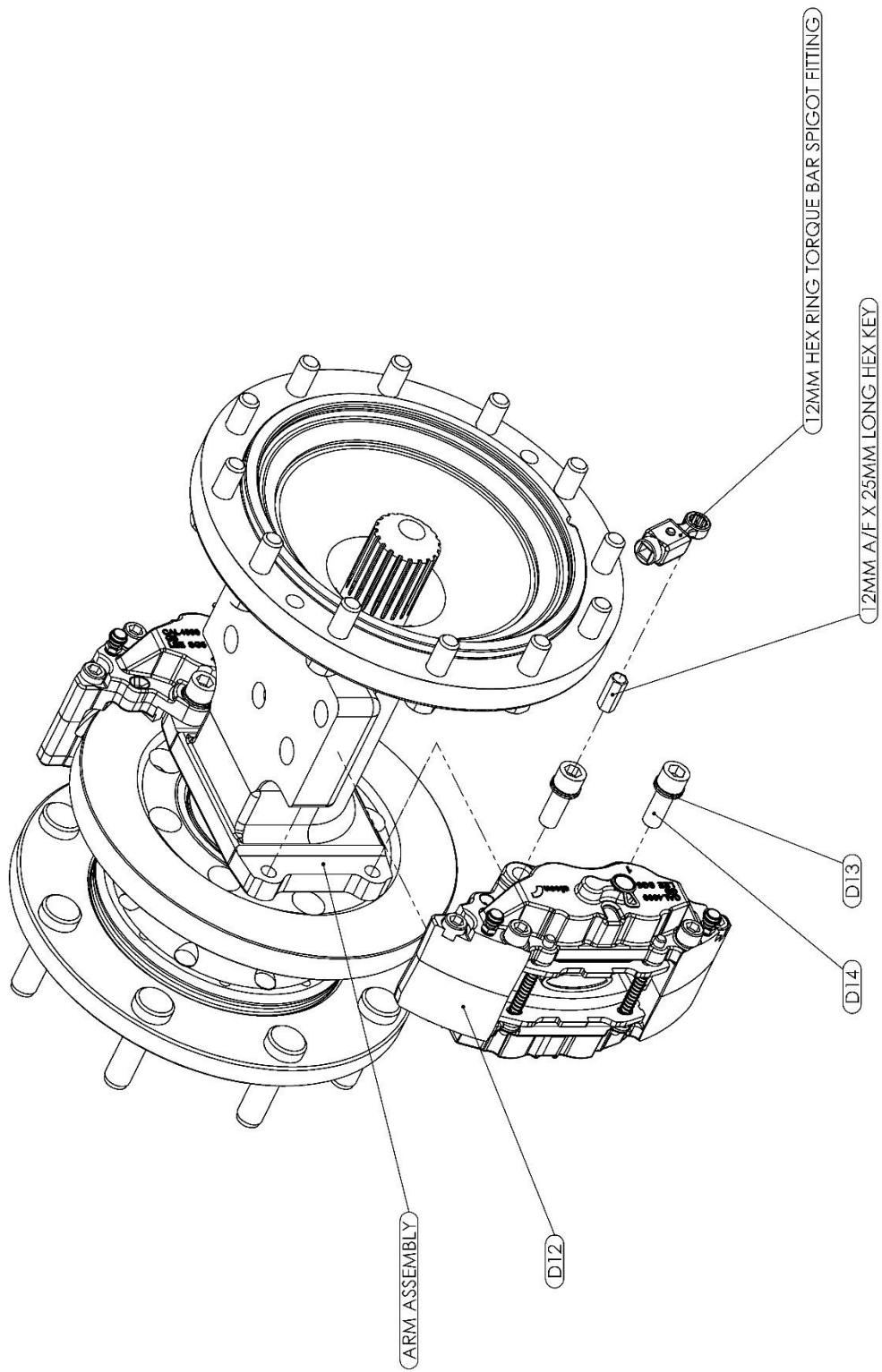

SERVICING AND REPAIRS – GENERAL



WARNING: Before carrying out any service work always ensure that the engine/motor is switched off

Before removal of the Axle for repair or overhaul, carefully study the following procedures. Use proper hand tools, slings and hoists for the job. **WORK SAFELY**

Keep all work areas, tools and Axle clean. All oil should be drained into a suitable container. Wipe up any spilled oil or fluids to prevent accidents. Wear correct safety equipment i.e. safety glasses and safety shoes to guard against personal injury

IMPORTANT NOTICE: ONLY REMOVE BREATHER, OIL DRAIN PLUG OR OIL LEVEL PLUG ONCE THE AXLE IS AT AMBIENT TEMPERATURE. REMEMBER HOT OIL CAN CAUSE BURNS – WORK SAFELY.



CAUTION: The above operations should be carried out by suitably qualified personnel and strictly in accordance with the procedures detailed in the workshop manual.

Drawings showing all internal components are contained in the parts lists at the back of this manual.

Seals

Remove Oil Seals carefully to prevent damage if they are to be re-used, however to prolong the life of the axle, it is best to replace these items.

Bearings

If removing taper roller Bearings for re-use keep them in matched sets and protect all Bearings from contamination.

Cleaning



WARNING: If using cleaning solvents these can be toxic, flammable, a skin irritant or give off harmful fumes. Avoid prolonged contact, vapour inhalation, or smoking. Failure to take care can result in injury or death. Refer to Material Safety data sheets prior to use.

Rinse all metal parts in cleaning solvent to remove dirt, grease and oil.

When fitting the Hub Seal (D10) to the Hub (D8 or D19) wipe both using cleaning solvent, Loctite SF7063 using a clean cloth.

Be careful to remove solvent from items before re-fitting.

INSPECTION

Main Case and Arms

Inspect for cracks. Check sealing surfaces for any imperfections, damage, etc. which will lead to oil leaks. Check all threads for damage.

Gears

Inspect for any chipped, broken or cracked gear teeth, also for any excessive wear i.e. progressive gear pitting.

Bearings

Inspect for any damage, progressive pitting or over-heating. Each time a Bearing is removed for inspection, or replacement it will be necessary to recalculate the required shim thickness to pre-load the Bearings correctly, see Procedures for more information.

Threaded Parts

Inspect for stripped or damaged threads.

PROCEDURES



CAUTION: When re-assembling the Axle all threaded fasteners must be tightened to the specified torques to prevent premature failure. Refer to Fastner Tightening Torque on Page 9.

Some servicing operations can be carried out with the Axle still mounted to the vehicle (provided, of course, that there is sufficient space); an example of this is the replacement or repair of the brake assemblies. The repair or replacing the Differential, Planetary Assemblies or Arm assemblies however will require the complete removal of the Axle from the vehicle.

NOTE: All procedures listed assume the Motor / Drive has already been removed from the Axle where required. This should be removed as detailed below.

If the details outlined below are carefully followed no difficulty will be found in stripping and rebuilding the Axle. It is most important that all components are perfectly clean and in good condition before reassembly.



CAUTION: The Crown Wheel and Pinion assemblies are supported by taper roller Bearings. Each time these are stripped for inspection, component repair or replacement it will be necessary to recalculate the number of Shims required to set the correct tooth markings and also to shim to the set pre-load for the Bearings correctly. Re-Shimming of the Axle is detailed under the Axle Shimming procedure.

Section 'A' – Axle Exploded Diagram

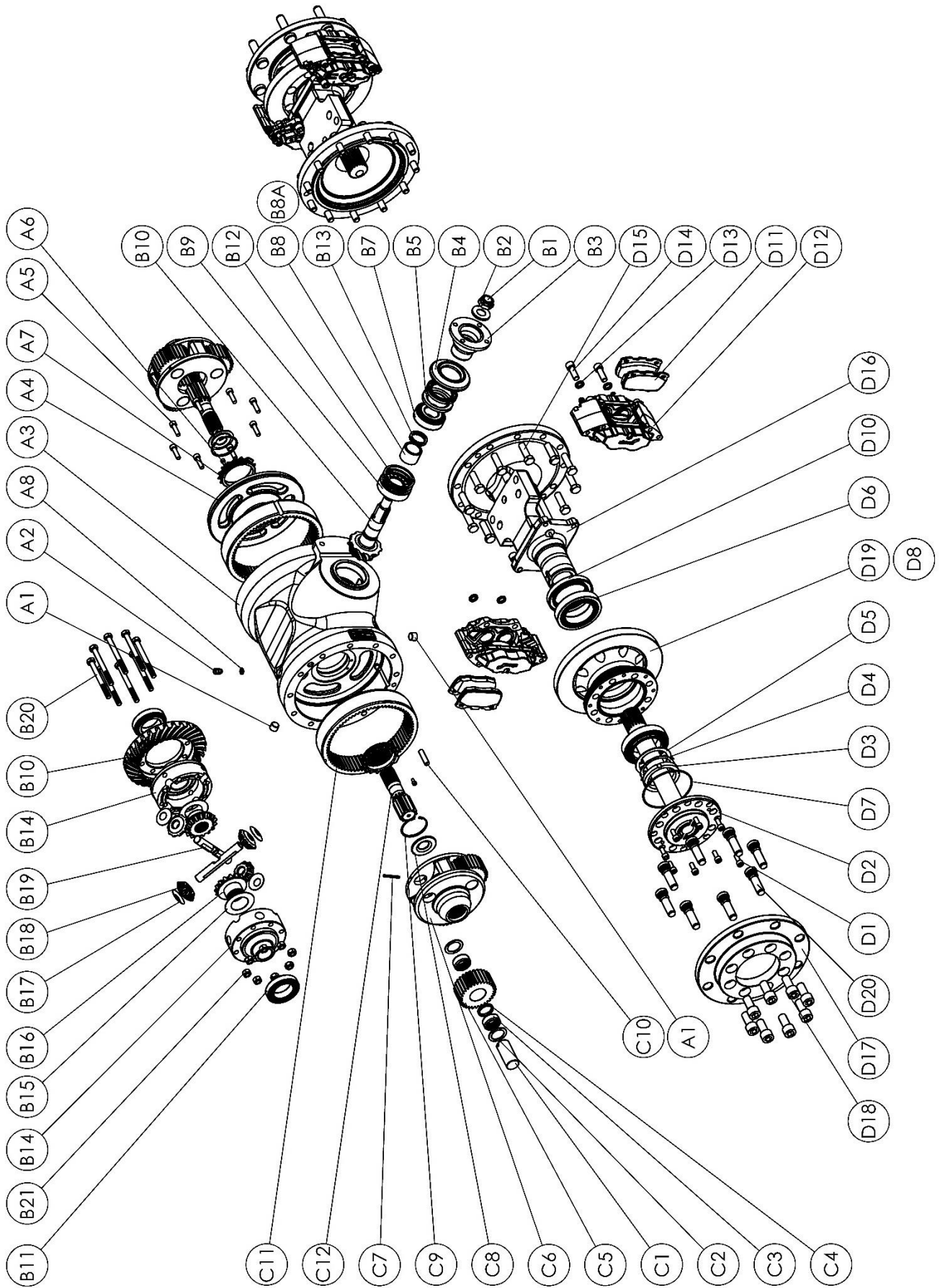

Section 'B' – Main Case and Differential Assembly

Item	Part No	Qty	Description
A1	0150250	2	Drain/Level Plug
A2	CP1498S/A	1	Breather
A3	612-0010	1	Main Case
A4	612-0731	1	Diff. Bearing Housing
A5	0081535	8	Cap Screw M10x35mm
A6	0081312P	2	Cap Screw M6x12mm
A7	915-2151	2	Bearing Adjuster Nut
A8	Part of CP1498S/A	1	Sealing Washer
B1	400-2200	1	M24 Nyloc Nut
B2	915-2190	1	Washer
B3 #	612-2180	1	Input Flange SAE1410 – 612B Axles
	612-2181	1	Park Brake Flange SAE1410 – 612PB Axles
B4	400-0910	1	Seal Cover
B5	002-0070V	1	Oil Seal Viton
B6	002-0070V	1	Oil Seal Viton
B7	055CU024H	1	Taper Roller Bearing
B8A	400-1050	1	Collapsible Spacer (0.9 mm wall thickness)
B8	216-2890/A,B,C,D,E	1	Spacer (5.4 mm wall thickness)
B9	055C026U057	1	Taper Roller Bearing
B10*	916-9820	1	Crown Wheel & Pinion Set
B11	0540552H	2	Taper Roller Bearing
B12	057340A 057340B 057340C	As Req	Shim 0.002" Shim 0.003" Shim 0.010"
B13	057189A 057189B 057189C 057189F	As Req	Shim 0.002" Shim 0.005" Shim 0.010" Shim 0.012"

*Includes 916-2000 Pinion and 916-2010 Crown Wheel. Matched Lapped pair can only be supplied.
B8 and B13 replaces B8A. # Drive Flange 612-2180 for Park Brake ready Axles, 612-2181 for use with Park Brake Axles.

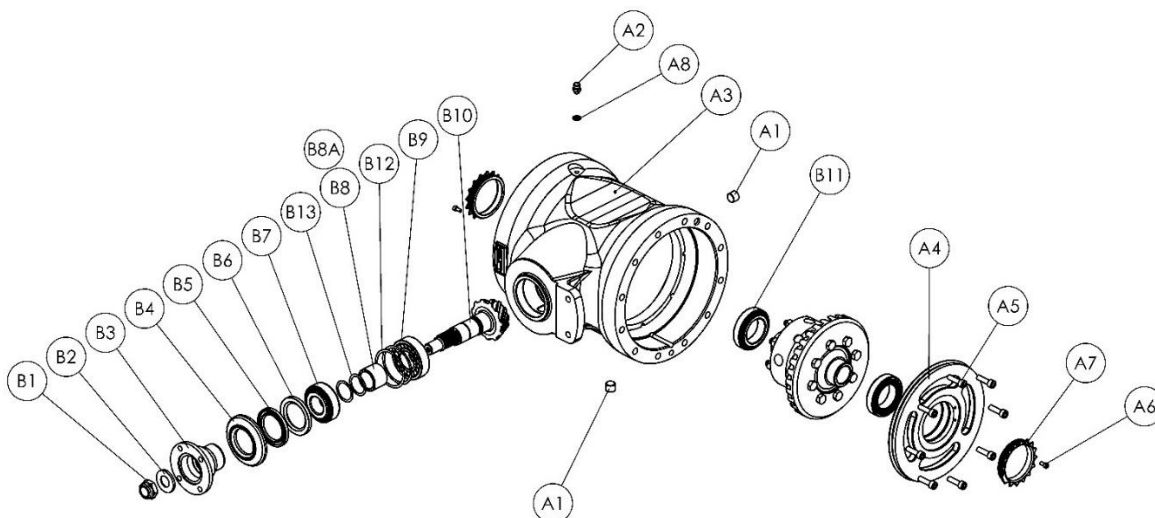

Item	Part No	Qty	Description
B14	612-9520	1	Differential Case
B15	915-2110	2	Thrust Washer
B16	915-2090	2	Differential Wheel
B17	915-2120	4	Thrust Washer
B18	915-2100	4	Differential Pinion
B19	915-2130	2	Spider
B10*	916-9820	1	Crown Wheel & Pinion Set (Pinion not shown)
B20	0041225HT	8	M12 Bolt
B21	007-0360	8	M12 Nyloc Nut

**Includes 916-2000 Pinion and 916-2010 Crown Wheel. Matched Lapped pair can only be supplied.*

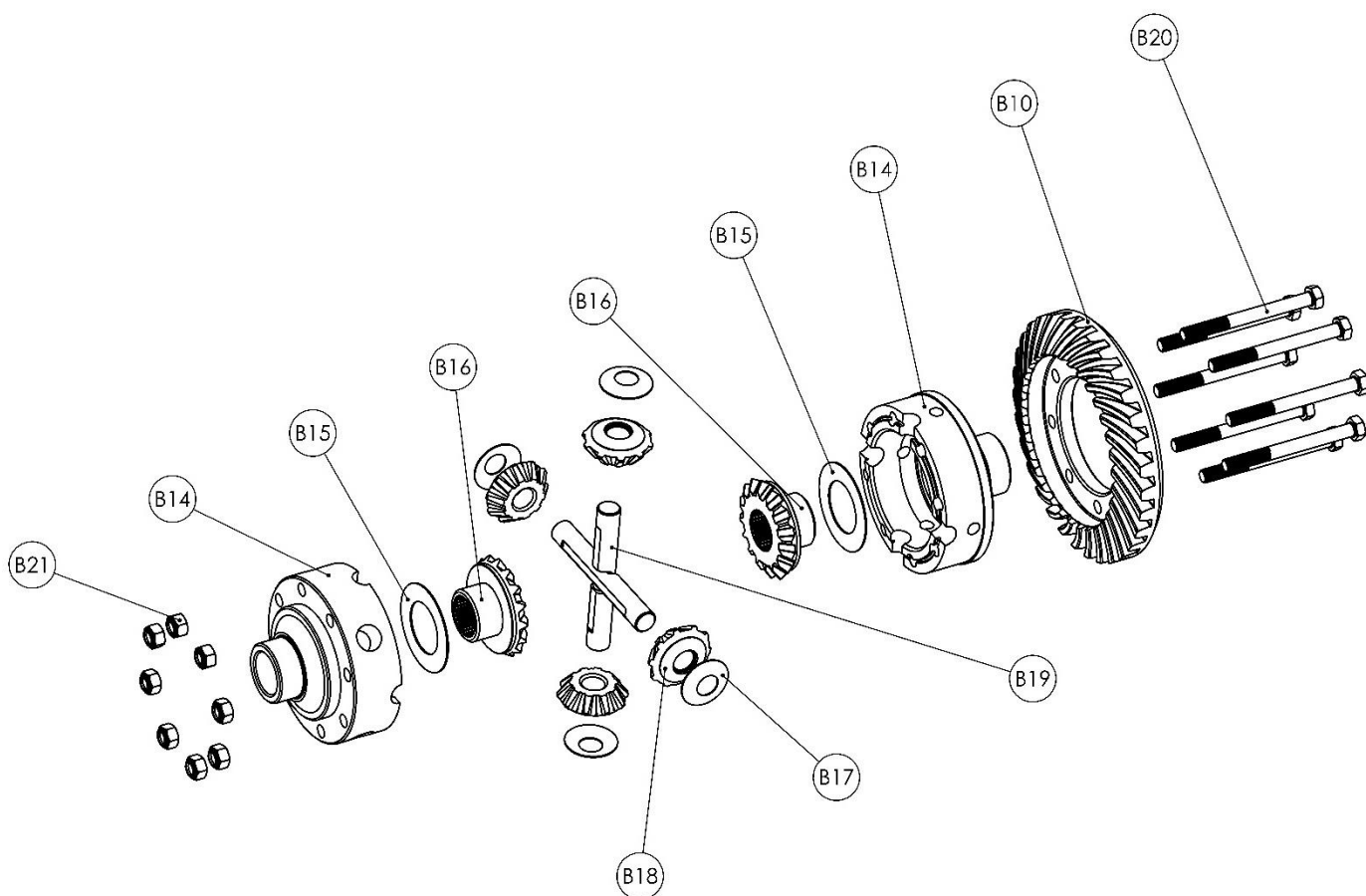

Servicing the Main Case and Differential Assemblies

Removing the Differential

1. Remove the Axle Arm Assemblies – see Section D
2. Remove the Axle Arm planetary Assemblies and Sun Gear – see Section C
3. Remove bolts (A6) from the Bearing Adjuster Nut (A7).
4. Unscrew and remove Adjuster Nuts (A7), 8 off Bolts (A5) and Bearing Housing (A4) using extractor screw holes, with bolts already removed. The Differential is now free and can be retracted.



CAUTION: Great care must be taken when removing the Differential Assembly from Main Case. Any damage to the Crown Wheel Bearings could be detrimental to the axles' performance.



WARNING: The space constraints around the Differential are very tight. The Differential Assembly weighs 20Kg, so ensure that you have a good grip on the Diff Casing before attempting to remove the assembly from the case. Do not drop the Differential Bearing Cups.

Servicing the Differential Assembly

1. Remove Nuts (B21) and Bolts (B20). The Crown Wheel (B10) is now loose and the Differential assembly will split into 2 halves. Turn the Differential vertically to avoid dropping any internal parts.
2. Remove the Differential Spider 2 off (B19) with the respective Differential Pinions (B18), Pinion Washers (B17), Differential Wheels 2 off (B16) & Thrust Washers 2 off (B15).
3. Inspect all Differential Wheels (B16), Differential Pinions (B18), Spiders (B19), Taper Roller Bearings (B11), Thrust Washers (B15) and pinion Washers (B17) for damage and wear, replace if necessary.
4. To assemble, reverse the above procedure.

NOTE: Markings on Differential Case must coincide.

5. If new Differential Taper Roller Bearings (B11) are fitted, it will be necessary to reset the Taper Roller Bearing pre-load and Crown Wheel/Pinion backlash (B10).

Removing the Pinion from the Main Case

1. Remove the M24 Nyloc Nut (B1), Washer (B2) and inspect the Flange & Seal Cover (B3 & B4)
2. Remove the Cap Screws 8 off (A5) and remove the Diff. Bearing Housing (A4) followed by the Diff Assembly (B14 to B21)
3. Carefully drift the Pinion (B10) through into the Main Case (A3). Do not lose the Shims (B12 & B13) or drop the loose Pinion Bearing (B7) or damage the Pinion teeth.
4. Inspect the Oil Seals (B5) for damage prior to fitment. Grease the seal lips and gently drift independently into position, with the second seal backing onto the first seal as illustrated.

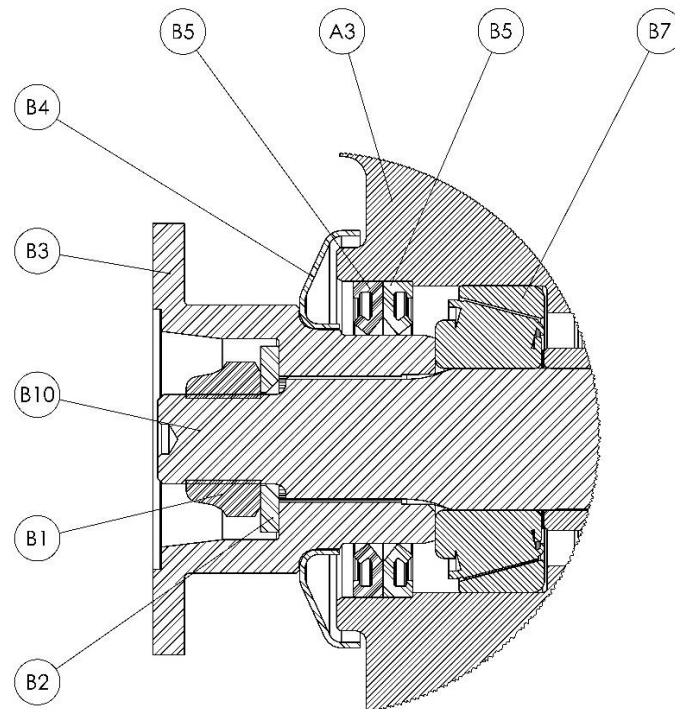

Pinion Shimming Procedure for tooth contact pattern of the Crown Wheel & Pinion (B10) with either Collapsible Spacer (B8A) or Solid Spacer (B8) used.

NOTE: The Shimming Procedure below assumes the Axle is stripped down following the above Service Procedures and details the reassembly and shimming of the Spiral Bevel Pinion (B10), and Crown Wheel (B11) Assembly into the Main Case (A3).

To Shim Pinion (B10) tooth contact pattern (example below):

If the Crown Wheel and Pinion (B10) or Pinion Head Taper Roller Bearing (B9) are replaced, the following procedure needs to be carried out for correct contact of the Crown Wheel & Pinion teeth:

1. Note the new Pinion (B10) mounting distance (etched as MD) on the bottom of the Pinion head. (Assume for e.g. 115.00mm)
2. Measure the new overall width of the Pinion Head Taper Roller Bearing (B9). (assume 30.16mm from cup to cone)
3. Note the Main Case (A3) Constant, this is 146.07mm
4. The required Shim (B12) thickness can then be calculated by using the following method: -
Main Case (A3) Constant – (Pinion (B10) Mounting Distance + Bearing (B9) Width).

Therefore, Shims (B12) Required using data above: -
Main Case Constant (A3) – (Pinion (B10) Mounting Distance + Bearing (B9) Width)
=146.07mm – (115.00mm +30.16mm)
=0.91mm required

Pinion Shimming Procedure for the Pinion Bearings (B7 & B9) Pre-Load using Solid Spacer (B8) & Shims (B13)

NOTE: This Procedure must be carried out after the Pinion Shimming Procedure for Contact.

1. Measure the actual overall length of the Slave Solid Spacer (B8) and Record "A"
2. Fit a Slave Solid Spacer with the counterbored recess towards the head bearing instead of the Collapsible Spacer.
3. Drift on the Taper Bearing (B7) onto the Pinion Shaft (B10) and fit the Slave Solid Spacer, Input Flange & Seal Cover (B3 & B4), Washer (B2) and tighten M24 Nyloc Nut (B1) to 250 lbft. Note the Drive Flange will have to be reacted through the Bolt holes to prevent rotation.
4. Magnetise a Dial Test Indicator (DTI) base to the Main Case (A3) and position the plunger on the end of the Pinion Shaft (B10)
5. Push and pull the Flange (B3) to record the Maximum Movement.
6. Calculate required the Spacer Length & Shim length to be made up from Solid Spacer (B8 plus Shims B13)
7. Solid Spacer and Shim required = Overall length of Slave Solid Spacer – Maximum Movement reading – 0.05 mm (0.002") pre load.
8. Fit the Solid Spacer (B8), with the internal counterbored recess towards the Pinion head Taper Roller Bearing(B9) and with the required Shims (B13) to make the calculated required length onto the Pinion Shaft (B10) from inside the Main case.
- 9.

Fitting the Pinion in the Main Case - Using Collapsible Spacer (B8A)

1. The Pinion Assembly (B1 to B10 & B12) should be fitted before the Crown Wheel and Differential Assembly (B10 & B14 to B21) are positioned.
2. Refit the Flange and Cover (B3 & B4)
3. Apply a small bead of sealant (Three Bond 120782) to the spline cavity and washer mounting face.
4. Fit a new washer (B2) and apply a bead of Loctite 243 to the first 3 threads.
5. Apply Loctite 243 to a new Nyloc Nut (B1) and tighten, which requires an initial high torque of 150 lb ft minimum, to collapse the Collapsible Spacer (B8). Apply a bead of Loctite 243 on the male thread of the Pinion (B10) until the Collapsible Spacer (B8) collapses and the entire end float between the Pinion Bearings (B7 & B9)
6. Refit Diff Bearing Assembly (B14 to B21) and Diff Bearing Housing (A4)
7. Fit Cap Screws (A5) and tighten to recommended tightening torque

NOTE: This must be carried out with the Crown Wheel/ Pinion (B10/B25) out of mesh.

Fitting the Pinion in the Main Case - Using Hard Spacer and Shims (B8 & B13)

1. The Pinion Assembly (B1 to B10 & B12 & B13) should be fitted before the Crown Wheel and Differential Assembly (B10 & B14 to B21) are positioned.
2. Fit Measured Solid Spacer (B8) and Shims (B13)
3. Refit the Flange and Cover (B3 & B4)
4. Apply a small bead of sealant to the spline cavity and washer mounting face.
5. Fit a new washer (B2) and apply a bead of Loctite 243 to the first 3 threads.
6. Fit a new M24 Nyloc Nut (B1) and tighten to 250lbft. Check drag torque 20/25 lbin is achieved this equates to 13 to 22 lbft of Taper Roller Bearing Pre-load.
7. Refit Diff Bearing Assembly (B14 to B21) and Diff Bearing Housing (A4)
8. Fit Cap Screws (A5) and tighten to recommended tightening torque

NOTE: This must be carried out with the Crown Wheel/ Pinion (B10) out of mesh.

Resetting Backlash:

1. Refit Crown Wheel (B10), Differential Assembly (B14-B21), with Bearings (B11) within the Differential Bearing Housing (A4) Tighten Cap Screws (A5) to the recommended torque and adjust the Bearing Adjuster Nuts (A7) into position to remove all backlash from the Crown Wheel & Pinion (B10) mesh.
2. Re-adjust the Bearing Adjuster Nuts to move the Crown Wheel out of mesh to achieve a 0.41/0.47 mm backlash, when measured on the HS1410 Drive Flange 3.75-inch bolt circle.
3. Tighten the Bearing Adjuster Nut (A7) opposite the Crown Wheel (B10) to 20Nm (15lbft) and fit new 1 off cap screw (A6) into hole in Adjuster Nut (A7). Check the opposing Bearing Adjuster Nut (A7) & tighten to 20Nm (15lbft). Lock in position using 1 off Cap Screw (A6) tightened to 21Nm (15lbft).

Section 'C' – Planet Carrier Assembly

Item	Part No	Qty	Description
C1	612-0250	3	Planet Pin
C2	915-0270	6	Thrust Washer
C3	0564502	6	Needle Roller Bearing
C4	612-2560	3	Spacer
C5	612-0080 613-0080 614-0080	3	Planet Gear 19.7:1 Only 13.2:1 Only 15.8:1 Only
C6	612-0060	1	Planet Carrier
C7	010-0030	3	Spring Pin
C8	400-1320	1	Spacer
C9	003-0120	1	Circlip
C10	0211620	1	Dowel
C11	612-0070 613-0070 614-0070	1	Annulus 19.7:1 Only 13.2:1 Only 15.8:1 Only
C12	612-0090 613-0090 614-0090	1	Sun Gear 19.7:1 Only 13.2:1 Only 15.8:1 Only

NOTE: Quantities stated per side (2 Assemblies per Axle)

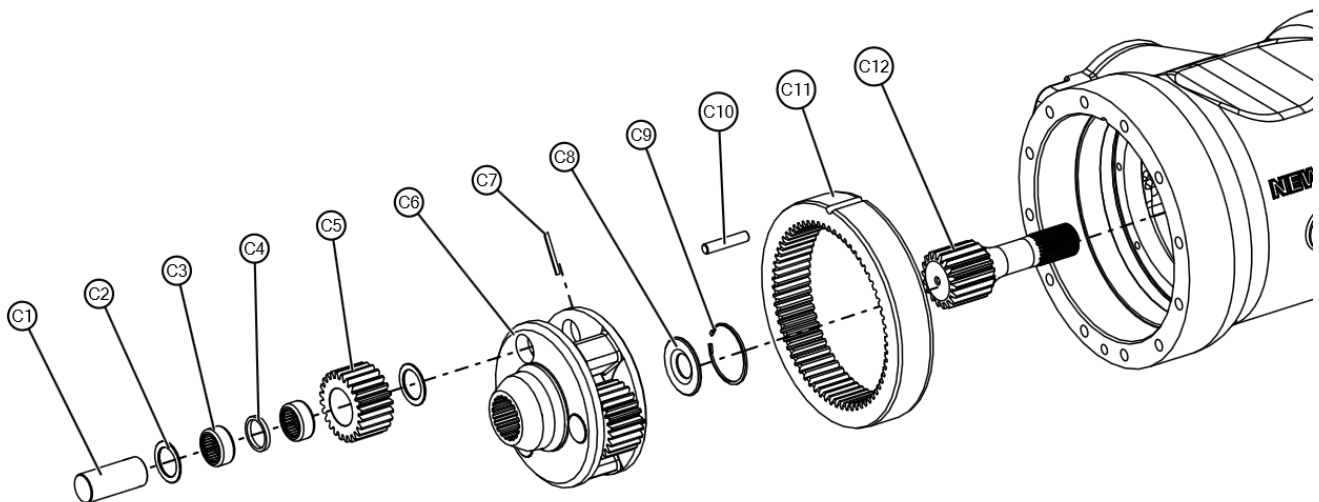

Servicing the Planet Carrier Assemblies

NOTE: This procedure assumes the Axle has had both arms removed – see section D.

1. The Planet Carrier Assembly (C1 to C9) can now be removed from the Main Case (A3). Take care not to withdraw the floating Sun Gear (C12).
2. Check the Planet Gears (C5) and the mating gear teeth on the Annulus (C11) and Sun Gear (C12) for damage and wear. The planet Gears (C5) should run free in the Planet Pins (C1), without excessive radial “play”. Replace if worn with new Needle Roller Bearing (C3).

NOTE: When servicing the Planet Assembly, we recommend all three Planet Gears (C5), Planet Pins (C1), Needle Roller Bearings (C3), Spring Dowels (C7), Annulus (C11) & Sun Gear (C12) are replaced together as they are in constant mesh.

3. To replace all the Planet Gears (C5), Planet Pins (C1) or Needle Roller Bearings (C3), drift each Spring Pin (C7) through the hole. Once the Spring Pin (C7) have been removed, lightly drift each Planet Pin (C1) through the Planet Gear (C5) bore and Planet Carrier (C6) bore. Remove the loose Planet Gears (C5), Thrust Washers (C2) and Needle Roller Bearings (C3). Remove Circlip (C9), which secures the Spacer (C8).

NOTE: The Spacer (C8) is fitted with the large central chamfer facing towards the Spline in the Planet Carrier (C6).

To reassemble:

1. With the Planet Carrier (C6) flat on a bench, refit the Spacer & Circlip (C8 & C9) and slide the Needle Roller Bearings (C3) into the Planet Gears (C5). Fit the bottom Thrust Washer (C2) over the machined boss within the Planet Carrier (C6), place the Planet Gear (C5) with the Needle Roller Bearing (C3) on top of the bottom Thrust Washer (C2) and another Thrust Washer (C2) on top of the Planet Carrier (C5) and from the top gently drift the Planet Pin (C1) through the Planet Carrier (C6), Thrust Washers (C2) & Planet Gear (C5).
2. Fit new Spring Pins (C7) into Planet Carrier (C6) and peen Planet Carrier (C6) to prevent Spring Pins (C7) from moving out of holes.

NOTE:

Removing the Annulus Gear

1. To remove Annulus (C11), use pinch bars, located behind the Annulus (C11) rear face, in a scissor fashion to prise the Annulus clear of the Main Case (A3) location bore and Dowel (C10). Be careful not to damage the internal gear teeth.
2. To refit, reverse procedure ensuring that the Dowel (C10) is aligned with the slot at the bottom of the Annulus (C11).

Section 'D' – Axle Arm, Hub and Brake Assemblies

Arm Assembly 8 Studs 9/16 x 18 UNF-3A on 6.5" PCD (165.1mm) (2 per axle)			
Item	Part No	Qty	Description
D1	0081525P	8	Cap Screw M10 x 25mm
D2	612-0100	1	Axle Shaft
D3	010N801	1	Lock Nut
D4	010W801	1	Lock Washer
D5	615-1440	1	Spacer
D6	0540803	2	Taper Roller Bearing
D7	0431343V	1	Viton "O" Ring
D8	612-0040	1	Wheel Hub
D9	512-0452	8	9/16" UNF Wheel Studs
D10	613-2850	1	Hub Seal
D11	612-2521-KIT	2	Ceramic Service Brake Pad Set (for 1 Wheel)
D12	614-2501	2	Brake Calliper (for 1 Wheel)
D13	0191314	4	Lock Washer
D14	00816A40MZP	4	M14 x 40mm Cap Bolt
D15	0041614HTP	12	M16 x 55mm Bolt
D16	613-0020 612-0021 612-0024 612-0025 612-0026 612-0027 612-0028 612-0029	1	Axle Arm Cast Rib Mounting Axle Arm Pad 28" Mounting 0 Deg L/H Axle Arm Pad 26" Mounting 6 Deg L/H Axle Arm Pad 26" Mounting 6 Deg R/H Axle Arm Pad 26" Mounting 2 Deg L/H Axle Arm Pad 26" Mounting 2 Deg R/H Axle Arm Pad 23.625" Mounting 4 Deg L/H Axle Arm Pad 23.625" Mounting 4 Deg R/H
D17	007-0400	8	Wheel Nut 9/16UNF (Not shown)
D23	612-2660	4	Service Brake Pad Retaining Pin
D24	612-2670	4	Service Brake Pad Spring
D25	024M2516	4	Service Brake Pad Split Pin

NOTE: Quantities stated per side (2 Assemblies per Axle)

Arm Assembly 8 Studs 9/16 x 18 UNF-3A on 6.5" PCD (165.1mm)

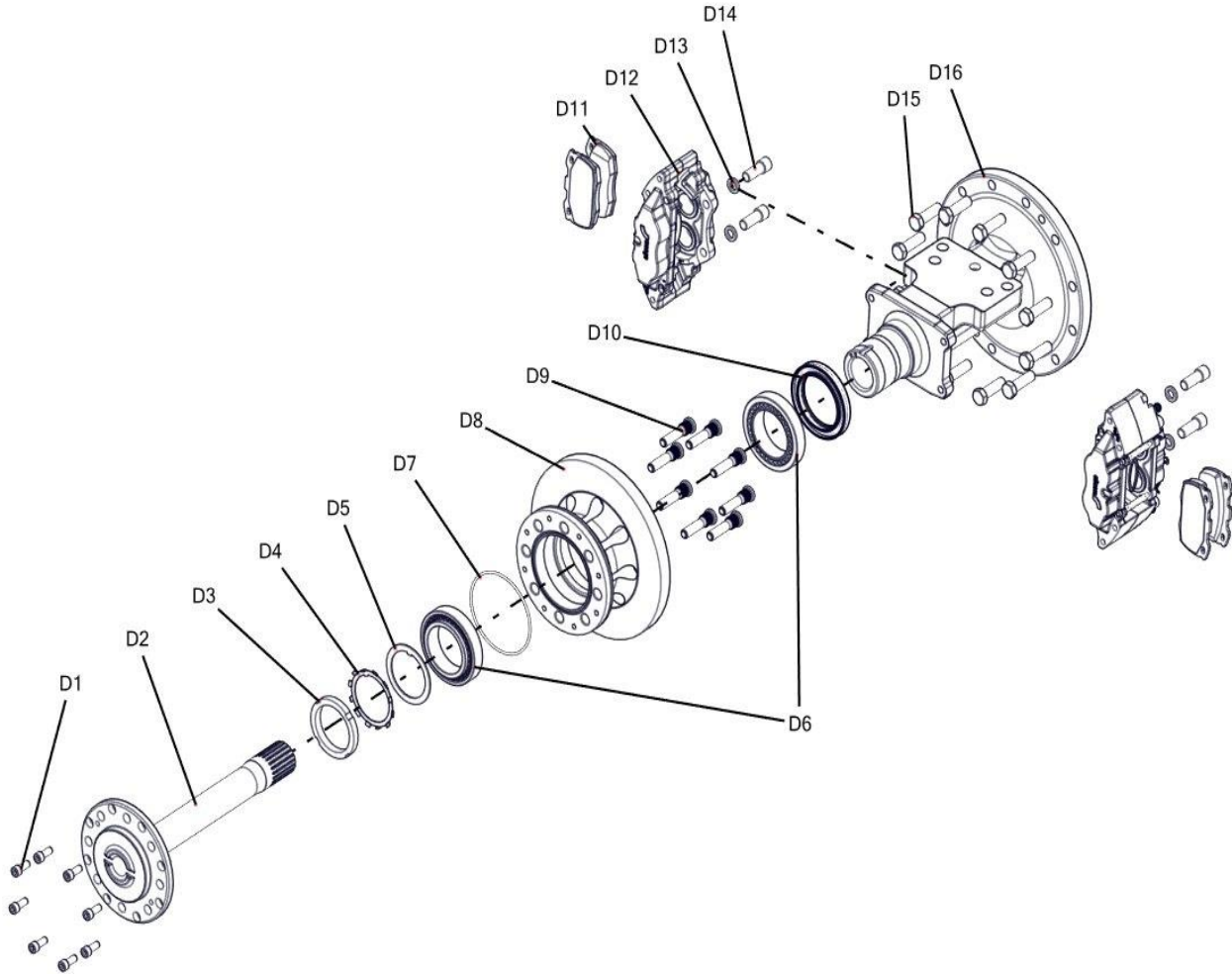

Arm Assembly 8 Studs M20 x 1.5 on 10.83" PCD (275mm) (2 per axle)			
Item	Part No	Qty	Description
D1	0081525P	8	Cap Screw M10 x 25mm
D3	010N801	1	Lock Nut
D4	010W801	1	Lock Washer
D5	615-1440	1	Spacer
D6	0540803	2	Taper Roller Bearing
D7	0431343V	1	Viton "O" Ring
D10	613-2850	1	Hub Seal
D11	612-2521-KIT	4	Service Brake Pad Set
D12	614-2501	2	Brake Caliper
D13	0191314	4	Lock Washer
D14	00816A40MZP	4	M14 x 40mm Cap Bolt
D15	0041614HTP	12	M16 x 55mm Bolt
D16	613-0020 612-0021 612-0024 612-0025 612-0026 612-0027 612-0028 612-0029	1	Axle Arm Cast Rib Mounting Axle Arm Pad 28" Mounting 0 Deg L/H Axle Arm Pad 26" Mounting 6Deg L/H Axle Arm Pad 26" Mounting 6Deg R/H Axle Arm Pad 26" Mounting 2Deg L/H Axle Arm Pad 26" Mounting 2Deg R/H Axle Arm Pad 23.625" Mounting 4Deg L/H Axle Arm Pad 23.625" Mounting 4Deg R/H
D17	612-0050	1	Hub Adaptor
D18	0081845	8	Cap Head M20 x 45mm
D19	613-0040	1	Wheel Hub
D20	613-0450	8	M20 x 1.5 Wheel Studs
D21	613-0100	1	Axle Shaft
D22	007-0410	8	M20 x 1.5 Wheel Nut (NOT SHOWN)
D23	612-2660	4	Service Brake Pad Retaining Pin
D24	612-2670	4	Service Brake Pad Spring
D25	024M2516	4	Service Brake Pad Split Pin

NOTE: Quantities stated per side (2 Assemblies per Axle)

Arm Assembly 8 Studs M20 x 1.5 on 10.83" PCD (275mm)

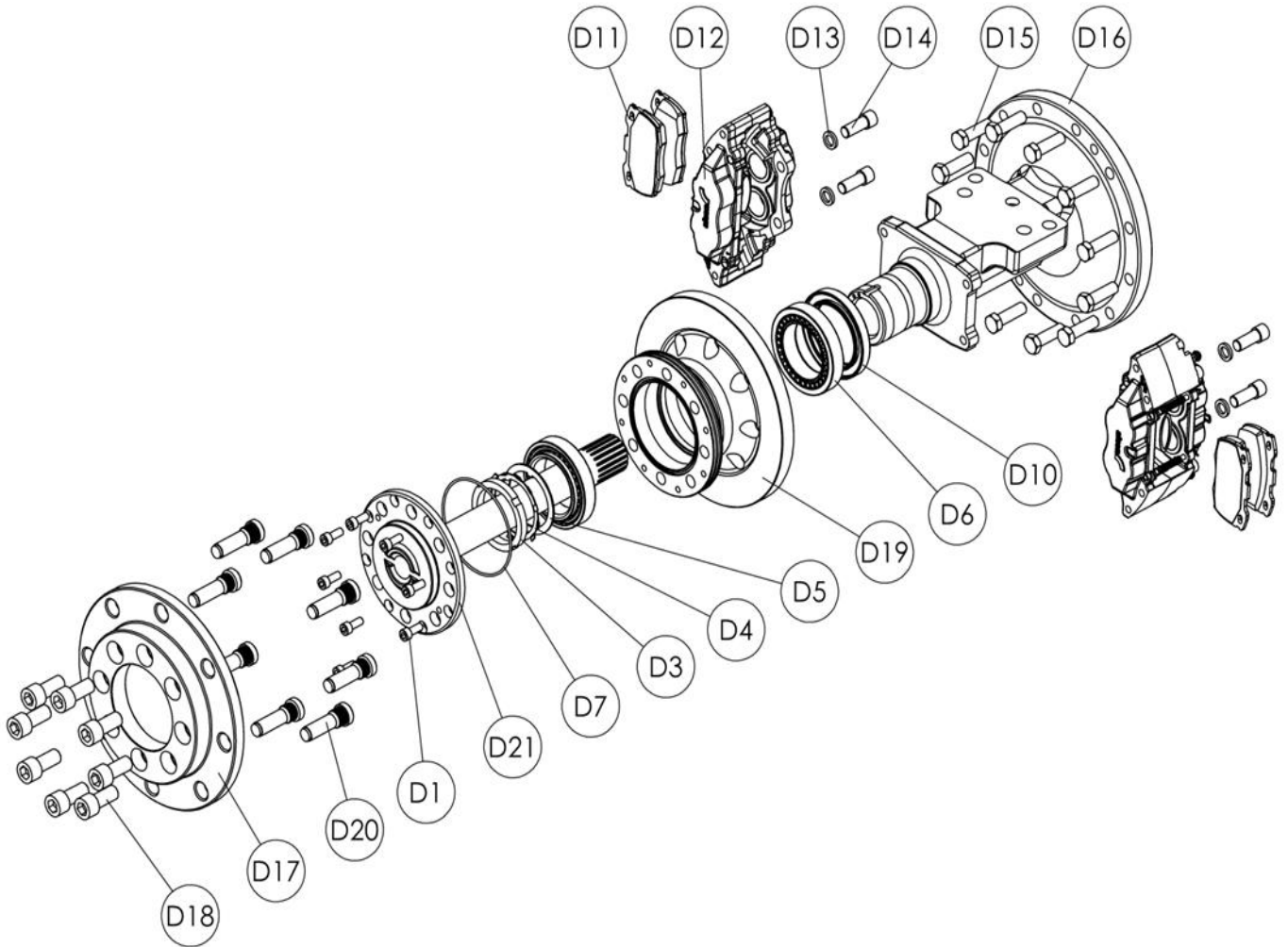

Servicing the Axle Arm, Hub and Brake Assemblies

The Hub assembly can be serviced with the Axle Arm (D16) still connected to the Main Case (A3). Procedure is as follows:

***Note If Servicing the Wheel Hub Assembly (D1 to D21) fitted with 8 Studs M20 x 1.5 on 10.83" PCD (275mm) first remove 8 Cap Head Bolts (D18) & remove Hub Adapter (D17) prior to using the procedure below. ***

1. Remove 8 Cap Head Bolts (D1) that secure Axle Shaft (D2 or D21) to the Wheel Hub/Brake Disc (D8 or D19). Withdraw the Axle Shaft (D2 or D21) using 2 off bolts (D1) removed as extraction screws, diametrically opposed & inspect the spline for damage & wear.
2. Remove Brake Calliper Bolts (D14) using a special tool ring spanner wrench and shortened Hexagon Allen Key (See Tooling Diagram Page 13) & and pull out the Brake Calliper (D12) radially from the Wheel Hub (D8 or D19).
3. Straighten locking tab ears on Lock Washer (D4), unscrew & remove the Lock Nut (D3) using a special tool (See Tool Drawing page 10).
4. Remove Lock Washer (D4) and Bearing Spacer (D5) from the keyway.
5. The Wheel Hub (D8 or D19) can now be withdrawn from the Axle Arm (D16) using a gentle tap from the mallet.

NOTE: Care must be taken not to drop the loose Bearing Cones from the stub arm axle.

6. Examine all Bearing Cups & Cones for wear or damage, replace as necessary.

NOTE: We recommend the Hub Seals (D10) are always changed when the Wheel Hub(D8 or D19 has been removed.

7. The Bearing Cups (D6) can be drifted out of the Wheel Hub (D8 or D19) if they need replacing. When fitting new Taper Roller Bearing cups (D6) ensure that they are aligned squarely to the bores before pressing in.

NOTE: If the Taper Roller Bearing (D6) are replaced Hub Seal (D10) will also need replacing.

8. To reassemble the wheel Hub assembly, reverse the above procedure using a new Lock Washer (D4).
9. To adjust the Wheel Hub Bearings:
 - i. Tighten the Lock Nut (D3) to the tightening torque of 135 Nm (100 lb.ft). When checking the torque setting, rotate the Wheel Hub (D8 or D19) 3 turns in each direction to ensure the Bearings have "seated" correctly and recheck tightening torque. Repeat this procedure 3 times.
 - ii. Slacken the Lock Nut (D3) back a distance equal to 1 tab of the new Lock Washer (D4) from the Lock Nut (D3) slot.
 - iii. Bend ear of Lock Washer (D4) over into the Lock Nut (D3) slot to secure the Lock Nut (D3)

NOTE: Always use a new Lock Washer (D4).

Servicing the Brake Pad Assemblies

Each Brake Assembly consists of two fixed Callipers per side (D12), so the Calliper needs to be removed from the Wheel Hub (D8 or D19) to replace the Pads.

1. Remove Calliper Guide Pins (D23) and Spring (D24), illustrated below, which are secured with Spring Retainers or Split Pins (D25) and pull the Brake Pads (D11) away from the Wheel Hub (D8 or D19).
2. Inspect for Pad wear and replace where necessary.

NOTE: It is recommended to replace all the Brake Pads (D11) at the same time to ensure consistent Brake performance and to ensure the same specification of Brake Pads are always used.

Always use a new Split Pin (D25).

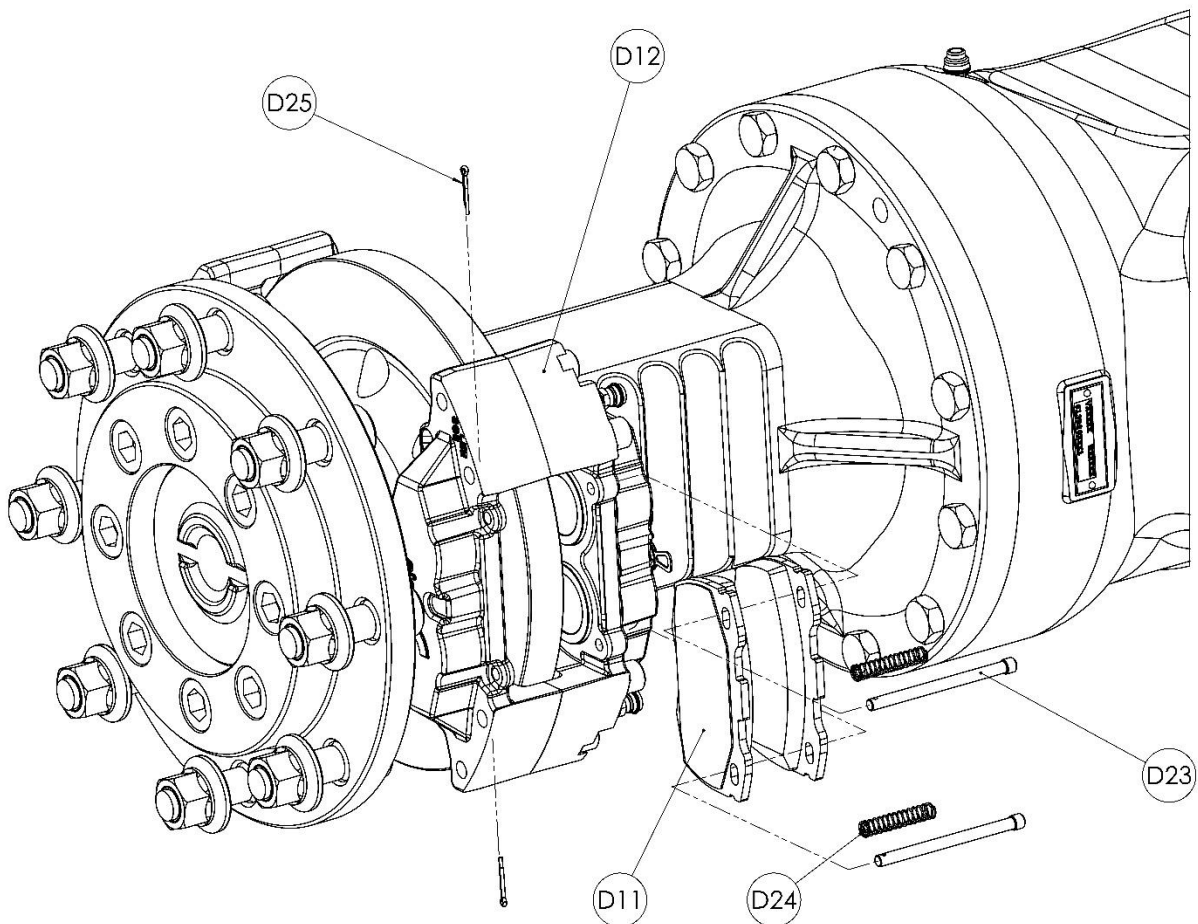

Section 'E' – Park Brake Assembly

NOTE: This only applies to 612PB specification axles.

Item	Part No	Qty	Description	B → PB Conversion
E1	512-2520	1	Park Brake Calliper	Bolt-on
B1	400-2200	1	M24 Nyloc Nut	
B2	915-2190	1	Washer	
B3	612-2181	1	Park Brake Rotor SAE1410	Remove 612-2180

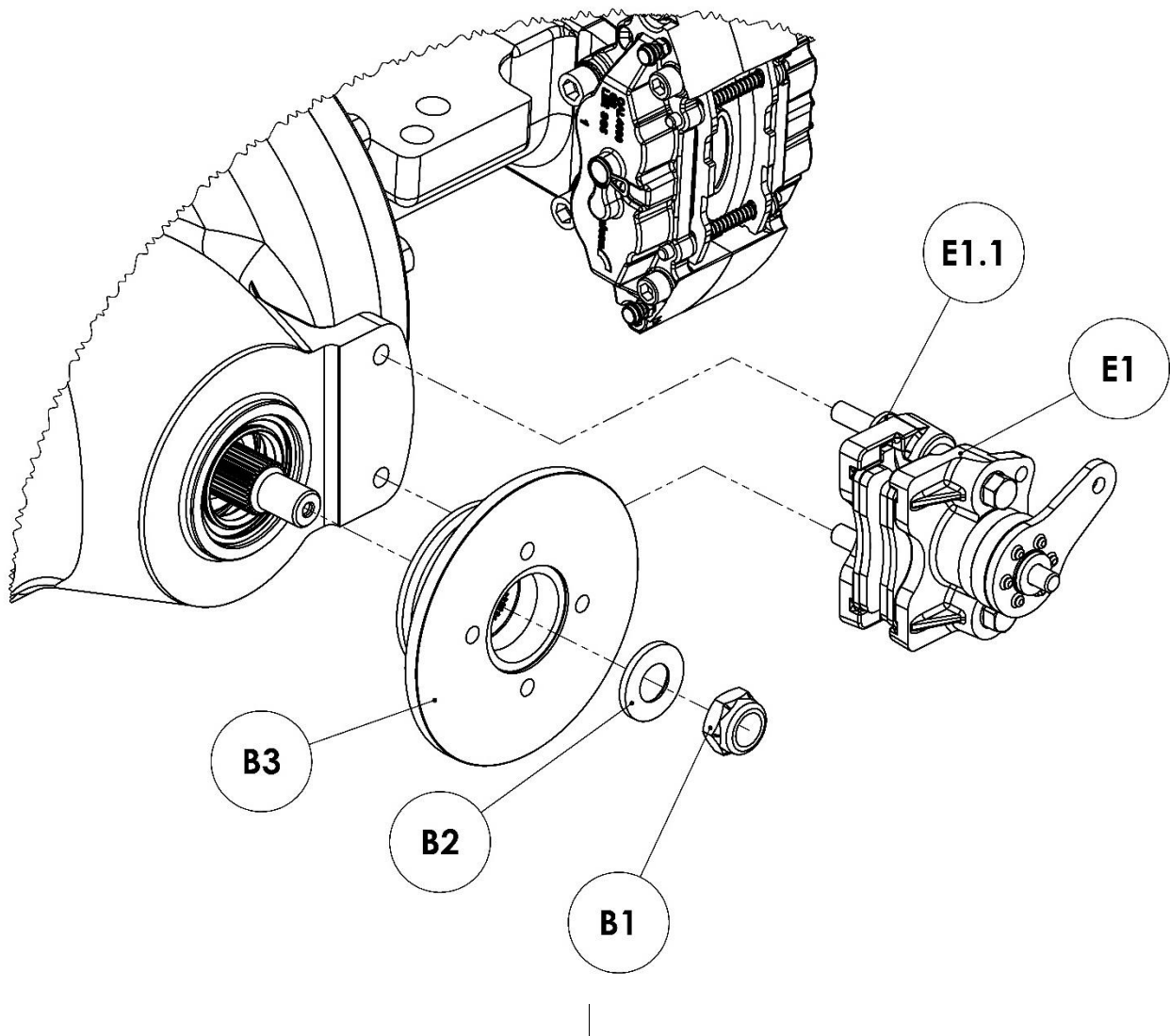

NOTE: Do not move or adjust the nuts (E1.1) as they are fitted to enable the Park Brake Caliper Assembly to float. If they are moved, a float of 0.06in (1.5mm) must exist between the Spacer and the Lock Nut for alignment & the Nut must be locked into position.

Servicing the Park Brake Assembly

1. Remove the Nuts and Washers from the Park Brake Caliper Bolts (E1).
2. Slide the Bolt assembly through the Main Case and Caliper (E1) holes towards the front of the Axle. The Caliper (E1) is now free to be removed radially away from the Park Brake Disc (B3).
3. To reassemble, follow procedure in reverse.



CAUTION: Great care must be taken when realigning the Park Brake Calliper with the Park Brake Disc. The Park Brake Calliper is self-aligning and so should have sufficient movement to slide along the Bolts.

Replacing the Park Brake Calliper Pads

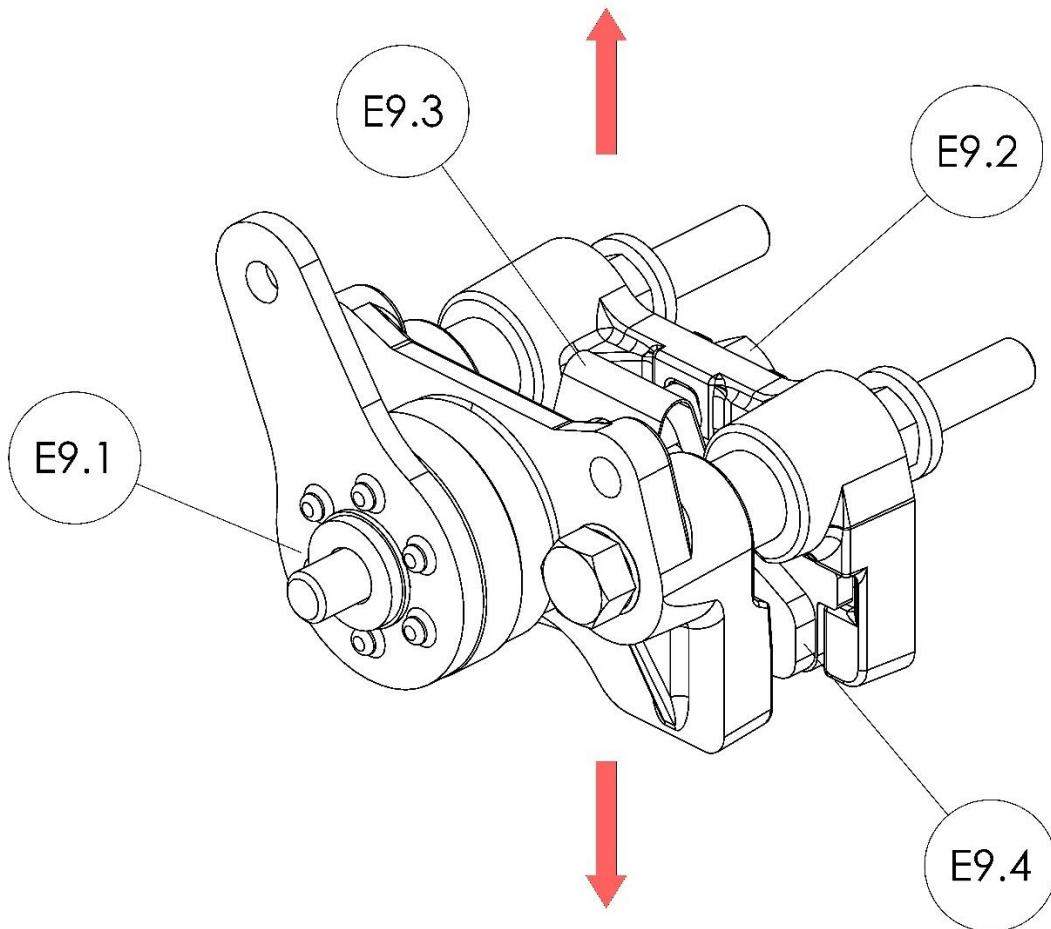

1. Loosen the Nut (E9.1) and slide the Bolt (E9.2) out through the Caliper body.
2. Remove the Spring (E9.3) once the Bolt (E9.2) has pass all the through the body.
3. The old Pads (E9.4) will slide out of the Caliper body.
4. Insert the new Pads and reposition the Spring (E9.3) so that it is reacting on the inside face of both Pads.
5. Reinsert the Bolt (E9.2) and tighten the Nut (E9.1).

Park Brake Overhaul

The Park Brake assembly is a ball and ramp, sliding caliper brake designed for use as a Park Brake. The Park brake has an open caliper design to facilitate changing the linings, along with a retraction spring to reduce parasitic drag. It is sealed from the environment to provide a long and trouble free service life.

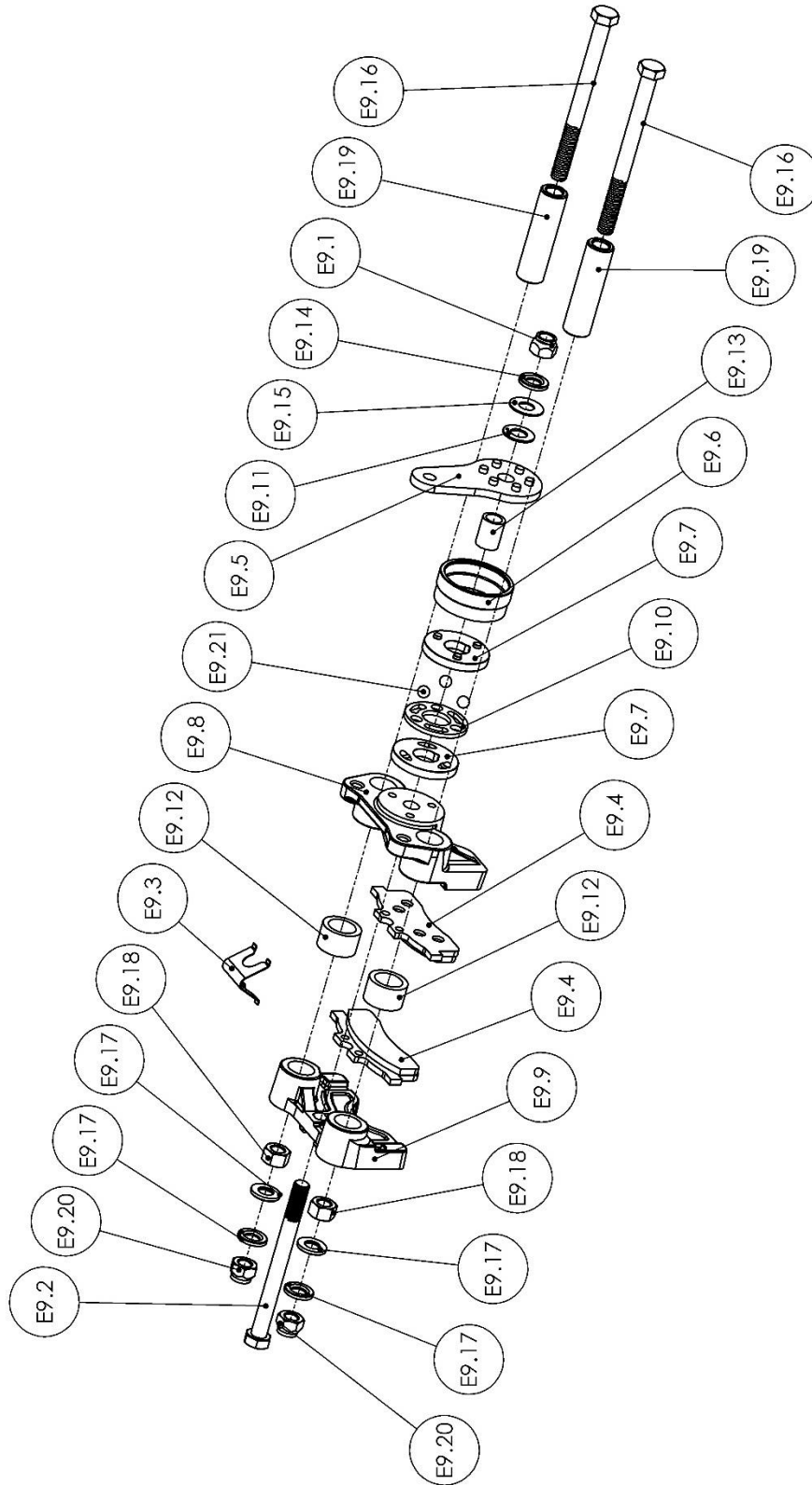

Mounting Procedure

1. Feed the Bolts (E9.16) together with a Washer (E9.17) through the Transfer Cases (A9 & A24).
2. Once just through the Case feed another Washer (E9.17), Nut (E9.18) and the Assembled Caliper (E9) pre-aligned with the Park Brake Disc (E5) and continue to tighten the Nut (E9.18) to clamp the Transfer Cases together.
3. Thread onto the Bolt (E9.16) the Locking Nuts (E9.20) until a 0.040" to 0.080" (1.00 mm to 2.00 mm) gap exists between the Sleeves (E9.19) and the Locking Nuts (E9.20).

Adjustment Procedure

1. Tighten Nut (E9.1) until firm contact is made between the Disc and the Linings. Torque to 35 N.m (25 lbf.ft), making sure the Lever (E9.5) is in the correct operating position for application.
2. Back off Nut (E9.1) 1 to 1.5 turns and check that the Disc is free to rotate.

Lining Replacement

1. Replace both linings when either has worn to 2.3mm (0.090") remaining thickness.
2. Loosen the Nut (E9.1) enough to slide each of the Torque Plates (E9.8 & E9.9) away from the Disc and far enough to provide clearance to remove the old Carrier/ Lining assemblies (E9.4) and install new ones.
3. Collapse the Lining Reaction Spring (E9.3) and remove from the brake head assembly.
4. Slide the Torque Plates (E9.8 & E9.9) away from the Disc and move the Carrier/ Lining assemblies (E9.4) out of the pockets and remove from the Brake Head Assembly from the side.

NOTE: PRIOR TO THE INSTALLATION OF THE NEW LININGS IT IS RECOMMENDED THAT "ALFA 2000" GREASE (ANTI-SEIZE & LUBRICATING COMPOUND) MANUFACTURED BY CHEMTOOL BE APPLIED TO THE INTERFACE OF THE SLEEVE (E9.19) AND THE TORQUE PLATES (E9.8 & E9.9). AFTER GREASE HAS BEEN APPLIED SLIDE THE TORQUE PLATES BACK AND FORTH ON THE SLEEVE AS FAR AS POSSIBLE TO ENSURE THAT GREASE HAS BEEN INTRODUCED INTO THE BORES OF THE TORQUE PLATES

5. Install new Carrier/ Lining assemblies (E9.4) in each of the Torque Plates (E9.8 & E9.9)
6. Install Lining Reaction Spring (E9.3) into the Brake Head Assembly, making sure that the feet on the springs locate securely into the holes in both Carrier/ Lining assemblies (E9.4)
7. Adjust Brake as per the ADJUSTMENT PROCEDURE.

PARK BRAKE ASSEMBLY – PART No. 512-2520		
Item	Description	Qty
E9.1	NUT ½" X 20 UNF NYLOC	1
E9.2	BOLT ½" X 20 UNF X 5.25" LONG	1
E9.3	SPRING FLAT	1
E9.4 *	LINING AND CARRIER ASSEMBLY – Part No. 613-2530	2
E9.5	LEVER	1
E9.6	BOOT	1
E9.7	CAM	2
E9.8	TORQUE PLATE FRONT	1
E9.9	TORQUE PLATE REAR	1
E9.10	BALL/ RETAINER SUB ASSEMBLY	1
E9.11	GARLOCK THRUST BEARING	1
E9.12	SEAL SLEEVE	2
E9.13	ID SEAL	1
E9.14	WASHER HARDENED	1
E9.15	WASHER	1
E9.16	BOLT ½" X 13 UNC X 5.75" LONG	2
E9.17	WASHER	4
E9.18	NUT ½" X 13 UNC	2
E9.19	SPACER SLEEVE	2
E9.20	NUT ½" X 13 UNC NYLOC	2
E9.21	3/8" BALL BEARING	3

NOTE: THE PARTS ABOVE ARE NOT AVAILABLE INDIVIDUALLY AND ARE SHOWN FOR ILLUSTRATION PURPOSES ONLY EXCEPT FOR THE * E9.4 REPLACEMENT BRAKE LINING AND CARRIER ASSEMBLY SUPPLIED AS 613-2530-KIT.

SPARES KITS

To ease the procurement of spares, we offer a catalogue of Kits that group common parts together to simplify the ordering process. These Kits are detailed below:

612-9630-KIT Differential Kit (1 Kit per axle)			
Item	Part No	Qty	Description
B14	612-9520	1	Differential Case
B15	915-2110	2	Thrust Washer
B16	915-2090	2	Differential Wheel
B17	915-2120	4	Thrust Washer
B18	915-2100	4	Differential Pinion
B19	915-2130	2	Spider
B20	0041225HT	8	M12 Bolt
B21	007-0360	8	M12 Nyloc Nut

612-9580-KIT (Uses 612-0070, 612-0080 & 612-0090) Planet Kit (2 Kits per axle)			
Item	Part No	Qty	Description
C1	612-0250	3	Planet Pin
C2	915-0270	6	Washer Thrust
C3	0564502	6	Needle Roller Bearing
C4	612-2560	3	Spacer
C5	612-0080	3	19.7:1 Only
	613-0080		13.2:1 Only
	614-0080		15.8:1 Only
C6	612-0060	1	Planet Carrier
C7	010-0030	3	Spring Pin
C8	400-1320	1	Spacer
C9	003-0120	1	Circlip
C10	0211620	1	Dowel
C11	612-0070	1	19.7:1 Only
	613-0070		13.2:1 Only
	614-0070		15.8:1 Only
C12	612-0090	1	19.7:1 Only
	613-0090		13.2:1 Only
	614-0090		15.8:1 Only

NOTE: 613-9580-KIT (Uses 613-0070, 613-0080 & 613-0090)

612-0040-KIT			
Brake Hub & Rotor Kit (8 Studs 9/16 x 18 UNF-3A on 6.5" PCD (165.1mm))			
(2 Kits Per Axle)			
Item	Part No	Qty	Description
D4	010W801	1	Lock Washer
D6	0540803	2	Taper Roller Bearing
D7	0431343V	1	Viton "O" Ring
D8	612-0040	1	Wheel Hub
D9	512-0452	8	9/16" UNF Wheel Studs
D10	613-2850	1	Hub Seal

613-0040-KIT			
Brake Hub & Rotor Kit (8 Studs 8 Studs M20 x 1.5 on 10.83" PCD (275mm))			
(2 Kits Per Axle)			
Item	Part No	Qty	Description
D4	010W801	1	Lock Washer
D6	0540803	2	Taper Roller Bearing
D7	0431343V	1	Viton "O" Ring
D10	613-2850	1	Hub Seal
D19	613-0040	1	Wheel Hub

612-0041-KIT			
Brake Hub Kit (8 Studs 9/16 x 18 UNF-3A on 6.5" PCD (165.1mm))			
(2 Kits Per Axle)			
Item	Part No	Qty	Description
D8	612-0040	1	HUB
D9	512-0452	8	WHEEL STUDS 9/16" UNF

612-0050-KIT			
Brake Hub Adaptor Kit (Hub Adaptor with 8 Studs M20 X 1.5 on 10.83" PCD (275mm))			
(2 Kits Per Axle)			
Item	Part No	Qty	Description
D17	612-0050	1	HUB ADAPTOR
D20	613-0450	8	WHEEL STUDS M20 X 1.5

612-9820-KIT Crown Wheel & Pinion (1 kit per axle)			
Item	Part No	Qty	Description
B5	002-0070V	2	Oil Seal Viton
B7	055CU024H	1	Taper Roller Bearing
B8	216-2890/A	1	Solid Spacer
B9	055C026U057	1	Taper Roller Bearing
B10	916-9820	1	Crown Wheel & Pinion Set
B12	057340A	2	SHIM .002" (Qty As Required)
B12	057340B	2	SHIM .003" (Qty As Required)
B12	057340C	2	SHIM .010" (Qty As Required)
B13	057189A	2	Shim 0.002" (Qty As Required)
B13	057189B	2	Shim 0.005 (Qty As Required)
B13	057189C	2	Shim 0.010" (Qty As Required)
B13	057189F	2	Shim 0.012" (Qty As Required)
Tool	216-2892Z	1	Slave Solid Spacer (Shimming Purpose)

614-2501 Service Brake Assembly			
Item	Part No	Qty	Description
D12	614-2501	4	Service Brake Assembly

612-2521-KIT Service Brake Pad Kit (2 Kits per axle)			
Item	Part No	Qty	Description
D11	612-2521	1	Set of 4 Brake Pads for 1 Wheel
D13	0191314	4	Lock Washer
D25	024M2516	4	Split Pin
D14	00816A40MZP	4	M14 x 40mm Cap Bolt
NOTE: "R" CLIP TO BE REMOVED FROM BRAKE ASSEMBLY & REPLACE WITH SPLIT PINS 024M2516			

612-2660-KIT Service Brake Pad Retaining Pin Kit (2 Kits per axle)			
Item	Part No	Qty	Description
D23	612-2660	4	Pad retaining Pin
D24	612-2670	4	Spring
D25	024M2516	4	Split Pin

613-2530-KIT Park Brake Pad Kit (1 Per Axle)			
Item	Part No	Qty	Description
E9.4	613-2530	2	Park Brake Pads

612-2510-KIT Park Brake Conversion Kit (1 Kit Per Axle)			
Item	Part No	Qty	Description
B3	612-2181	1	Rotor
B4	400-0910	1	Seal Cover (Fitted to 612-2181)
B2	915-2190	1	Washer
B1	400-2200	1	M24 x 2 Nyloc Nut
E1	512-2520	1	Park Brake Calliper Assembly (Including Bolts and Nuts)

Individual Parts			
Item	Part No	Qty	Description
B1	400-2210	1	Nut M24 x 2
B2	915-2190	1	Washer
B3 *	612-2180	1	Input Flange SAE1410 – 612B Axles
B3 *	612-2181	1	Park Brake Flange SAE1410 – 612PB Axles
B4 *	400-0910	1	Oil Seal Cover
A2	CP1498S/A	1	Breather
A1	0150250	2	Level/ Drain Plug
A4	612-0731	1	Diff. Bearing Housing
A5	0081535	8	Cap Screw M10 x 35mm
D1	0081525	16	Cap Screw M10 x 25mm
D2	612-0100	2	Axle Shaft
D3	010N801	2	Lock Nut
D4	010W801	2	Lock Washer
D5	615-1440	2	Spacer
D13	0191314	4	Lock Washer
D14	00816A40MZP	4	M14 x 40mm Cap Bolt
D15	0041614HTP	12	M16 x 55mm Bolt
D21	613-0100	1	Axle Shaft

*NOTE: PARTS B3 & B4 ARE SUPPLIED AS A SUBASSEMBLY PART NUMBERS 612-2180S/A OR 612-2181S/A

613-2850-KIT Hub Seal & Breather Kit (1 kit per axle)			
Item	Part No	Qty	Description
A2	CP1498S-A	1	Breather
D4	010W801	2	Locking Washer
D1	0081525P	16	Cap Bolt M10 x 25
D7	0431343V	2	"O" Ring – Viton
D10	613-2850	2	Hub Oil Seal - Viton

All spares are available from your local Newage distributor. Check our website www.prm-newage.com to find your closest distributor.

Other spares are available upon request; however, these may not be carried by the distributor as standard stock and may incur a delivery lead-time.

SPIRAL BEVEL GEAR TOOTH CONTACT

Contact may vary, but generally is approximately in the tooth centre, equi-spaced between root and tip. The marking may be towards toe on some gears on both flanks or marking crossed slightly i.e. towards toe on convex flank and heel on concave flank or vice versa.

Apply gear marking compound on both sides of 7 to 10 teeth on the Crown Wheel (B10). Whilst applying resistance to the Pinion (B10) rotate the Crown Wheel back and forth (Not Full revolutions) until a clear contact pattern is shown. Compare the contact pattern to the illustrations below and re-shim the Pinion Bearing bore in the Main Case (A3).

If the Taper Roller Pinion Bearing (B9) is Re-shimmed (B12) the backlash must be re-set between the Crown Wheel and Pinion (B10).

Go back and repeat all procedures in setting the backlash.

Correct Pattern



Ideal contact pattern
Correct shim
Correct backlash

Incorrect Pattern

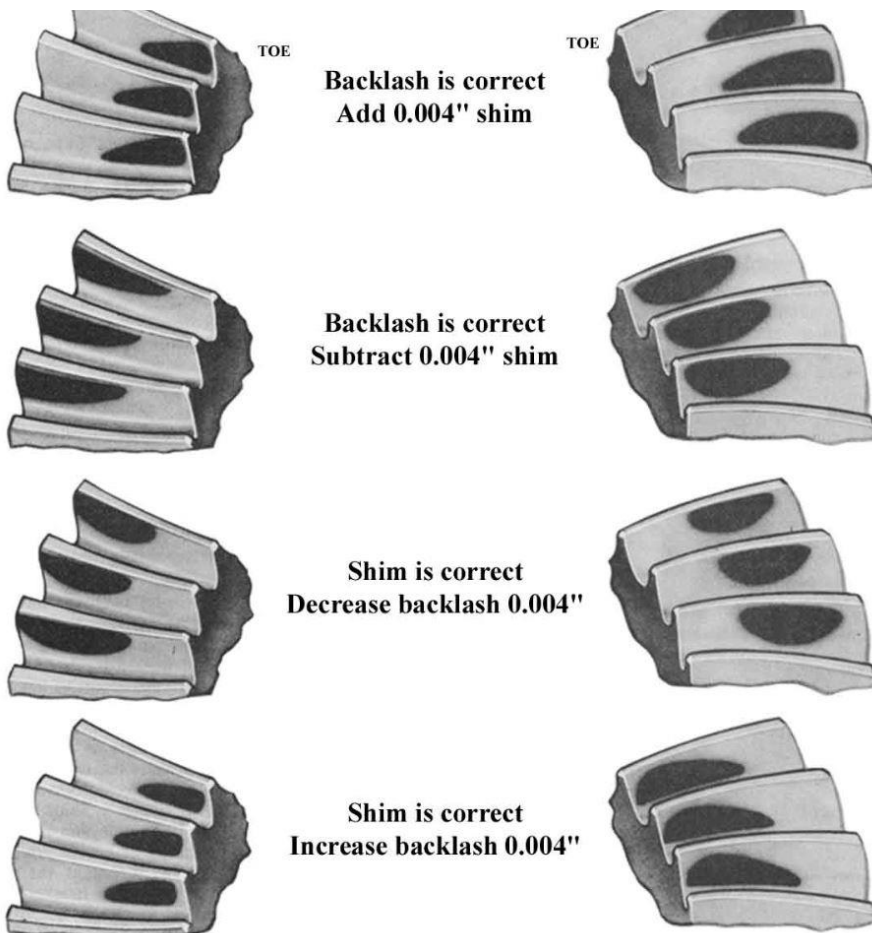

Backlash is correct
Add 0.004" shim

Backlash is correct
Subtract 0.004" shim

Shim is correct
Decrease backlash 0.004"

Shim is correct
Increase backlash 0.004"

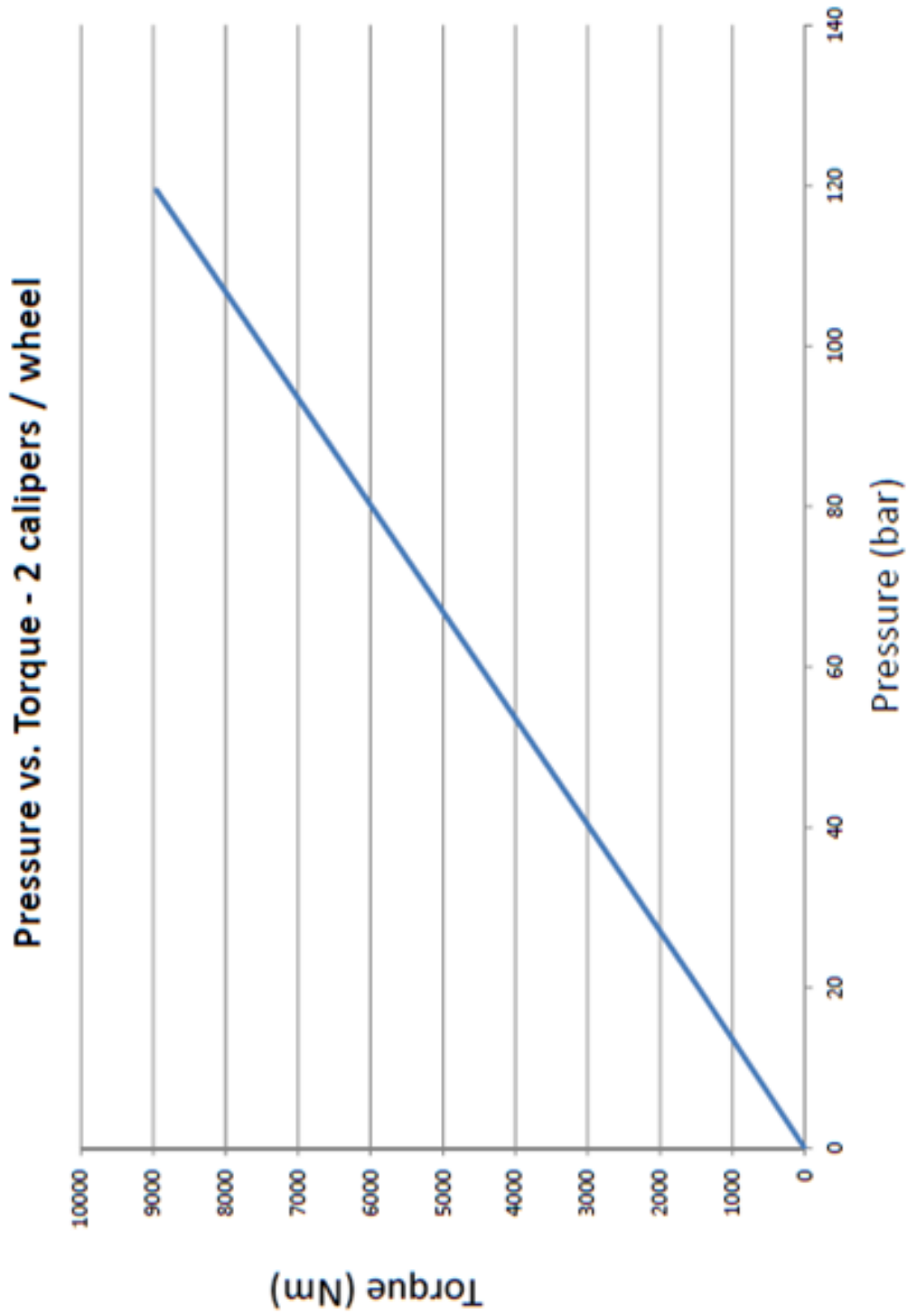

Appendix 2 :-

Park Brake Graph

